

EcoQuip 2™ EQs, EQc, and EQ Trailer Unit 3A7467E Vapor Abrasive Blast System

EN

***Vapor abrasive blast system for coating removal and surface preparation.
For professional use only.***

175 psi (12.06 bar, 1.2 MPa) Maximum Working Pressure

See page 4 for models and approval information.



Important Safety Instructions

Read all warnings and instructions in this manual before using this equipment.
Save these instructions.

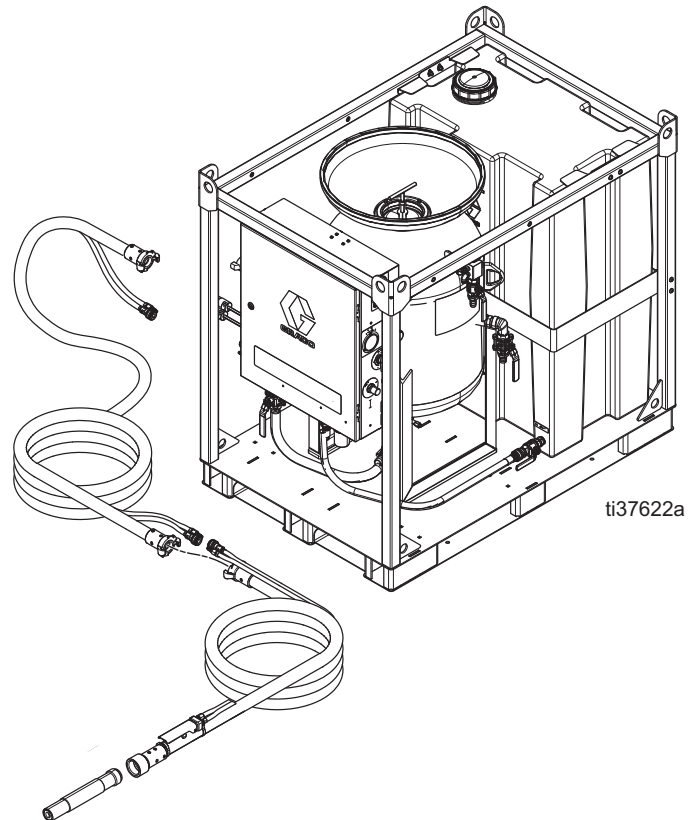

Contents

Related Manuals	3	Repair	35
Models	4	Replace the DataTrak Battery	35
Series Change Information	5	Replace the DataTrak Fuse	36
Packages	6	Replace the Pinch Hose	37
Warnings	7	Parts	38
Component Identification	10	EQs Parts	38
MediaTrak Controls	11	EQc and EQ200T / EQ400T Models	42
Installation	12	EQ200T Parts	44
Grounding (ATEX systems only)	12	EQ400T Parts	46
Lifting the System	12	Enclosure Box Parts	48
Blast Hose Control Selection	13	Enclosure Parts	52
Blasting on Higher Surfaces	13	Blast Hoses	54
Pinch Hose Inspection	13	Vapor Abrasive Blast Systems and	
Connect the Blast Hose and Air Hose	14	Accessories	56
Connect the Water Supply	15	50 ft (15 m) Blast Hoses with Control	
Setup	16	Hose/Cable	56
Fill the Water Tank	16	50 ft (15 m) Blast Hoses without Control	
Fill Pot with Abrasive Media	17	Hose/Cable	56
Pressurize the Pot	18	Control Hoses/Cable with Blast Hose	56
Operation	19	Nozzles	57
Pressure Relief Procedure	19	EQ200T (M58 Kaeser Compressor)	57
Adjust Blast Pressure	20	EQ400T (Atlas Copco Compressor)	57
Adjust Abrasive Media	20	Other Accessories	57
Refill Pot with Media	21	Common Spare Parts	58
Set the Abrasive Metering Value	21	Tubing Schematic	59
Optimize the Abrasive Metering Value	21	Dimensions	60
General Application Guides	22	EQs and EQs Elite Models	60
Nozzle Selection Guide	23	EQc Models	60
Blast Pressure vs. Air Flow Guide	23	EQ Trailer Models	61
Use the Wash Feature	24	Trailer Kit Compressor Installation Guidelines	
Standby	25	(279960, 279970)	62
Shutdown	25	Trailer Mounting Area Dimensions	62
Drain the Pot	26	Technical Specifications	64
Winterize the Equipment	27	EQs Elite	64
Clean the Water Tank	28	EQc and EQc Elite	65
Use the Water Dose Meter	28	EQ200T Elite	66
Troubleshooting	29	EQ400T Elite	67
		California Proposition 65	67
		Graco Standard Warranty	68

Related Manuals

Manual in English	Description
3A3489	EcoQuip EQm Vapor Abrasive Blast System
313840	DataTrak™
333397	Pump
335035	Air Inlet Kit
309474	Low Pressure Fluid Regulators
3A3470	Hose Rack Kit
3A3838	Nozzle Pressure Verification Kit
3A3839	Nozzle Extension Handle Kit
3A3970	Water Dose Kit

Models

EcoQuip 2 Vapor Blast Systems					
Model	Part Number	Series	Blast Control		Approvals
			Pneumatic	Electric	
EQs	262960	D	✓	✓	CE
	262961	C	✓		CE Ex II 2 G Ex ia h IIA T3 Gb X
EQs Elite	262970	D	✓	✓	CE
	262971	C	✓		CE Ex II 2 G Ex ia h IIA T3 Gb X
EQc	273200	D	✓	✓	CE
	273201	C	✓		CE Ex II 2 G Ex ia h IIA T3 Gb X
EQc Elite	273204	D	✓	✓	CE
	273207	C	✓		CE Ex II 2 G Ex ia h IIA T3 Gb X
EQ200t Elite	279990	C	✓	✓	Tier 4 final
EQ400t Elite	279980	C	✓	✓	Tier 4 final

Series Change Information

The EcoEquip pressure pot has been updated with a new pop-up assembly and the addition of a quick drain ball valve assembly to simplify the process for filling and draining the pot.

Non-ATEX Systems Series D (262960, 262970, 273200, 273204)

ATEX System Series C (262961, 262964, 262971, 262974, 273201, 273209, 273207, 273210)

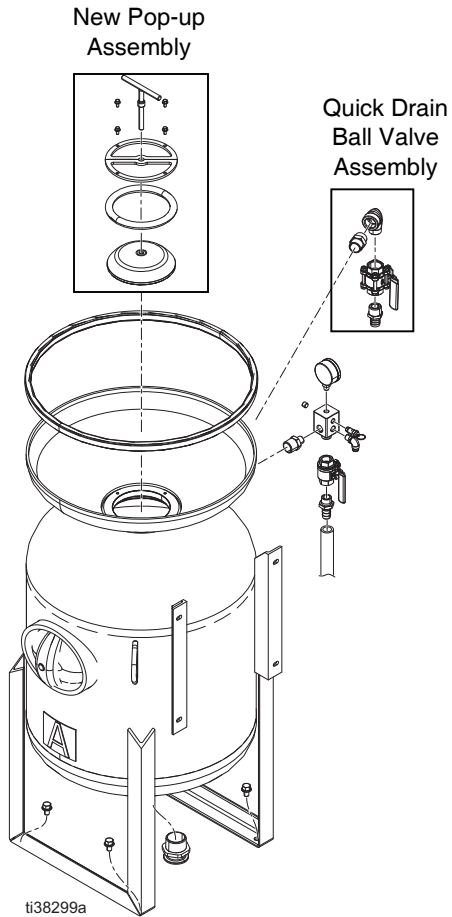







Packages

NOTE: Packages include a blast hose with electric or pneumatic blast controls and a tool kit.

EcoQuip 2 Vapor Blast System Packages						
Model	Package	Included System	Blast Control		Blast Hose	Nozzle
			Pneumatic	Electric		
EQs	262962	262960	✓		100ft, 1.25 in. ID	#8 High Performance
	262963			✓		
	262964	262961	✓			
EQs Elite	262972	262970	✓		100ft, 1.25 in. ID	#8 High Performance
	262973			✓		
	262974	262971	✓			
EQc	273202	273200	✓		50 ft, 1.25 in. ID	#8 Standard
	273203			✓		
	273209	273201	✓			
EQc Elite	273206	273204	✓		50 ft, 1.25 in. ID	#8 High Performance
	273208			✓		
	273210	273207	✓			

Warnings

The following warnings are for the setup, use, grounding, maintenance, and repair of this equipment. The exclamation point symbol alerts you to a general warning and the hazard symbols refer to procedure-specific risks. When these symbols appear in the body of this manual or on warning labels, refer back to these Warnings. Product-specific hazard symbols and warnings not covered in this section may appear throughout the body of this manual where applicable.

 <h1 style="margin: 0;">WARNING</h1>	
 	<p>SPECIFIC CONDITIONS OF USE (ATEX systems only)</p> <ul style="list-style-type: none"> • Ground all equipment in the work area. See Grounding (ATEX systems only) Instructions. • All label and marking material must be cleaned with a damp cloth (or equivalent).
 	<p>DUST AND DEBRIS HAZARD</p> <p>Use of this equipment can result in the release of potentially harmful dust or toxic substances from the abrasive being used, the coatings being removed, and the base object being blasted.</p> <ul style="list-style-type: none"> • For use only by sophisticated users familiar with applicable governmental safety and industrial hygiene regulations. • Use equipment only in a well-ventilated area. • Wear a properly fit-tested and government approved respirator suitable for the dust conditions. • Follow local ordinances and/or regulations for disposal of toxic substances and debris.
 	<p>PRESSURIZED EQUIPMENT HAZARD</p> <p>Fluid from the equipment, leaks, or ruptured components can splash in the eyes or on skin and cause serious injury.</p> <ul style="list-style-type: none"> • Follow the Pressure Relief Procedure when you stop spraying/dispensing and before cleaning, checking, or servicing equipment. • Tighten all fluid connections before operating the equipment. • Check hoses, tubes, and couplings daily. Replace worn or damaged parts immediately.



WARNING



EQUIPMENT MISUSE HAZARD

Misuse can cause death or serious injury.

- Do not operate the unit when fatigued or under the influence of drugs or alcohol.
- Do not exceed the maximum working pressure or temperature rating of the lowest rated system component. See **Technical Specifications** in the equipment manuals.
- Do not use this equipment without hose restraints and coupler pins installed on all air and blast hose couplings.
- Do not blast unstable objects. The high amount of fluid flow from the nozzle can potentially move heavy objects.
- Do not exceed load ratings of lift eyes.
- Do not operate equipment on or stand on an unstable support. Keep effective footing and balance at all times.
- Use fluids and solvents that are compatible with equipment wetted parts. See **Technical Specifications** in all equipment manuals. Read fluid and solvent manufacturer's warnings. For complete information about your material, request Safety Data Sheets (SDSs) from distributor retailer.
- Never use 1, 1, 1-trichloroethane, methylene chloride, other halogenated hydrocarbon solvents or fluids containing such solvents in pressurized aluminum equipment. Such use could result in a chemical reaction, with the possibility of explosion.
- Do not leave the work area while equipment is energized or under pressure.
- Turn off all equipment and follow the **Pressure Relief Procedure** when equipment is not in use.
- Check equipment daily. Repair or replace worn or damaged parts immediately with genuine manufacturer's replacement parts only.
- Do not alter or modify equipment. Alterations or modifications may void agency approvals and create safety hazards.
- Make sure all equipment is rated and approved for the environment in which you are using it.
- Use equipment only for its intended purpose. Call your distributor for information.
- Route hoses and cables away from traffic areas, sharp edges, moving parts, and hot surfaces.
- Do not kink or over bend hoses or use hoses to pull equipment.
- Keep children and animals away from work area.
- Comply with all applicable safety regulations.



BURN HAZARD

Equipment surfaces and fluid that is heated can become very hot during operation. To avoid severe burns:

- Do not touch hot fluid or equipment.







FIRE AND EXPLOSION HAZARD

Flammable fumes, such as solvent, in work area can ignite or explode. To help prevent fire and explosion:

- Use equipment only in well ventilated areas.
- Abrasive material exiting blast nozzle can generate sparks. When flammable liquids are used near the blast nozzle or for flushing or cleaning, keep the blast nozzle at least 20 feet (6 meters) away from explosive vapors.
- Ground all equipment in the work area. See **Grounding (ATEX systems only)** instructions.
- Keep work area free of debris, including solvent, rags and gasoline.
- Keep a working fire extinguisher in the work area.



 <h1 style="margin: 0;">WARNING</h1>	
 	<p>MOVING PARTS HAZARD</p> <p>Moving parts can pinch, cut, or amputate fingers and other body parts.</p> <ul style="list-style-type: none"> • Keep clear of moving parts. • Do not operate equipment with protective guards or covers removed. • Pressurized equipment can start without warning. Before checking, moving, or servicing equipment, follow the Pressure Relief Procedure and disconnect all power sources.
	<p>PERSONAL PROTECTIVE EQUIPMENT</p> <p>Wear appropriate protective equipment when in the work area to help prevent serious injury, including eye injury, hearing loss, inhalation of toxic fumes, and burns. Protective equipment includes but is not limited to:</p> <ul style="list-style-type: none"> • Protective eyewear and hearing protection • Protective clothing, shoes and gloves • Properly fit-tested and government approved respirator suitable for the dust conditions
	<p>RECOIL HAZARD</p> <p>Blast nozzle may recoil when triggered. If you are not standing securely, you could fall and be seriously injured.</p>

Component Identification

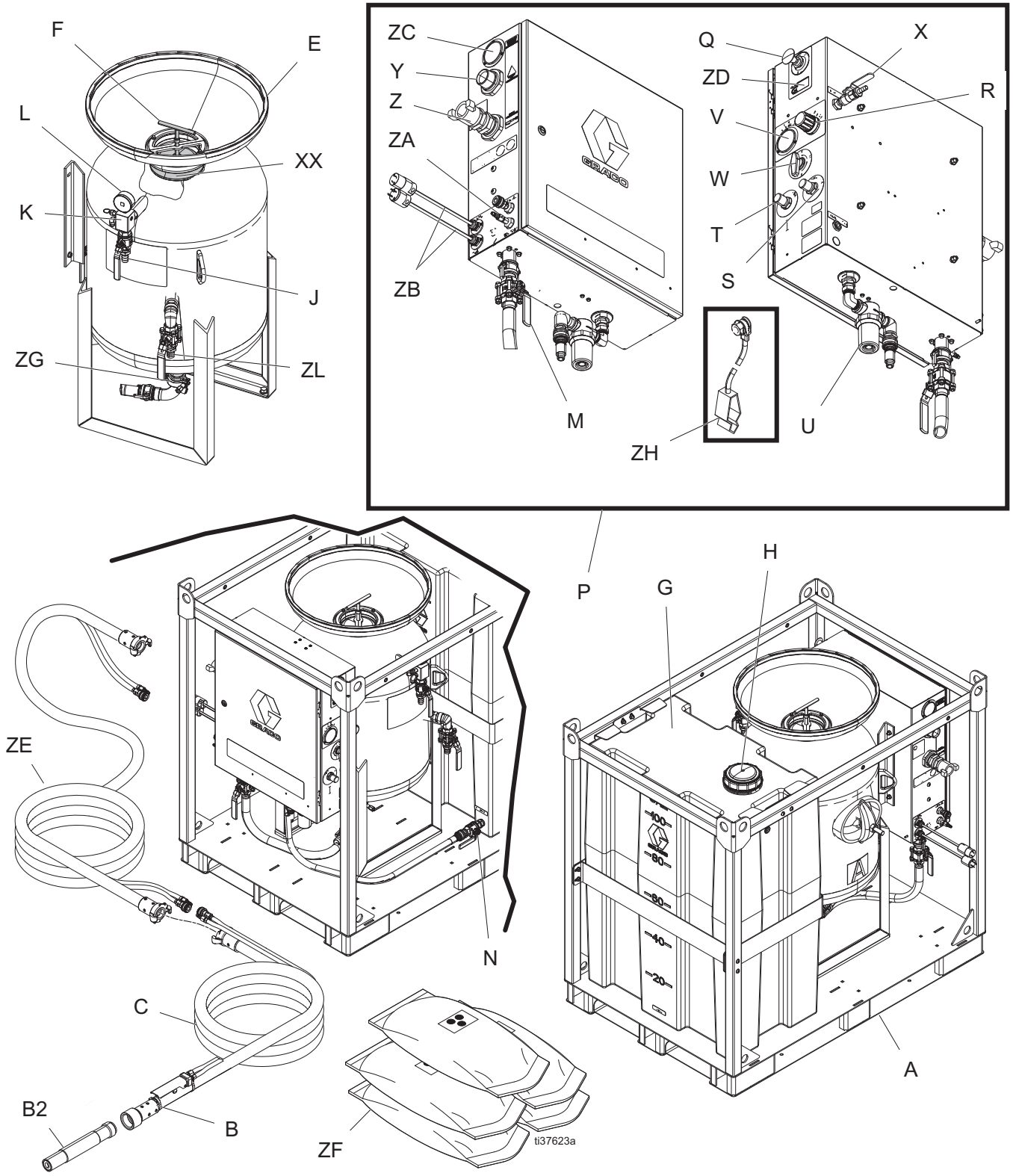

Key:

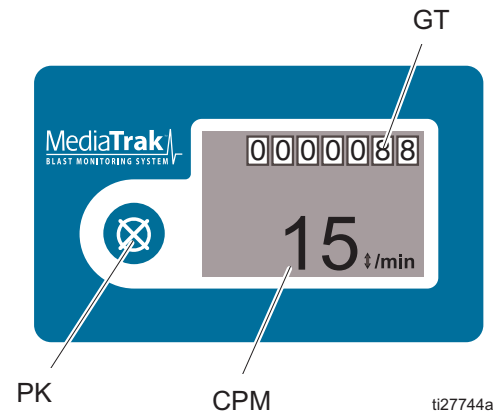

A	Frame
B	Blast Control Switch
B2	Blast Nozzle
C	Blast Hose
E	Pot
F	Pop-up Handle
G	Water Tank
H	Water Tank Lid
J	Pot Dump Valve
K	Pressure Relief Valve
L	Pot Pressure Gauge
M	Abrasive Ball Valve
N	Inlet Ball Valve
P	Control Box
Q	Emergency Stop
R	Blast Air Regulator
S	Water Dose Valve
T	Abrasive Metering Valve
U	Water Pump Inlet Filter
V	Blast Air Pressure Gauge
W	Selector Valve
X	Rinse Ball Valve
Y	Air Supply Connection
Z	Blast Connection
ZA	Pneumatic Control Connection
ZB	Electric Control Connection (non-ATEX systems only)
ZC	Supply Pressure Gauge
ZD	MediaTrak
ZE	Accessory Extension Hose
ZF	Abrasive Material (not included)
ZG	Pot Outlet Manifold
ZH	Ground Wire and Clamp (ATEX systems only)
XX	Pop-up Seal
ZL	Quick Drain Valve

MediaTrak Controls**Key:**

PK	Power Key
CPM	Cycle/Rate
GT	Grand Totalizer

Installation

Grounding (ATEX systems only)

				
<p>The equipment must be grounded to reduce the risk of static sparking. Static sparking can cause fumes to ignite or explode. Grounding provides an escape wire for the electric current.</p>				

Systems: Use supplied ground wire and clamp (237686).

Air and fluid hoses: Use only genuine Graco conductive blast hoses with a maximum of 150 ft (45 m) combined blast hose length to ensure grounding continuity. Check the electrical resistance of the blast hoses. If the total resistance to ground exceeds 29 megaohms, replace the blast hose immediately.

Air compressor: Follow manufacturer's recommendations.

Lifting the System

- Only lift the system using all available lift points. During an EQs system lift, the lift chains must be angled at least 45° from the horizontal.
- Before lifting the system, drain the water tank and pot of water and media.
- Lift the system with a lift apparatus rated appropriately for the weight of the system. See **Technical Specifications**, page 64.
- Lift the system using the lift eyes shown on the appropriate illustration.

EQs and EQs Elite Models:

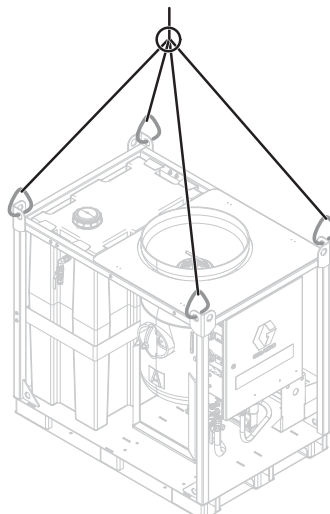

ti28153a

EQc Models:

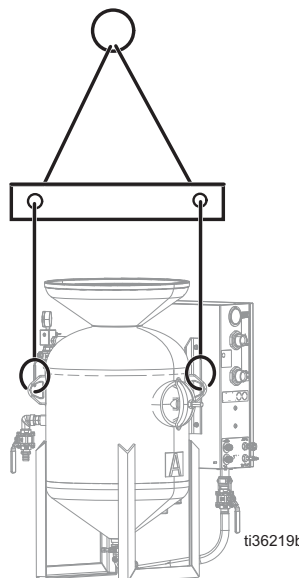

ti36219b

Blast Hose Control Selection

Make sure to use the correct type of blast control. Either an electric or pneumatic blast control switch can be used with hose lengths less than 150 ft (45 m). Blasting with 150 ft (45 m) or more of blast hose requires the use of an electric blast control switch.

Blasting on Higher Surfaces

NOTICE

When blasting on a surface higher than the equipment, make sure that there is a length of blast hose on the ground equal to 10-20% of the height. The hose on the ground prevents unspent abrasive in the hose from backing up into the internal plumbing of the panel, which can cause damage to the main air regulator when the blast switch is disengaged.

For example: When blasting 50 feet (15 m) straight up, use at least 10 feet (3 m) of blast hose on the ground before the blast hose goes up to the blasting height.

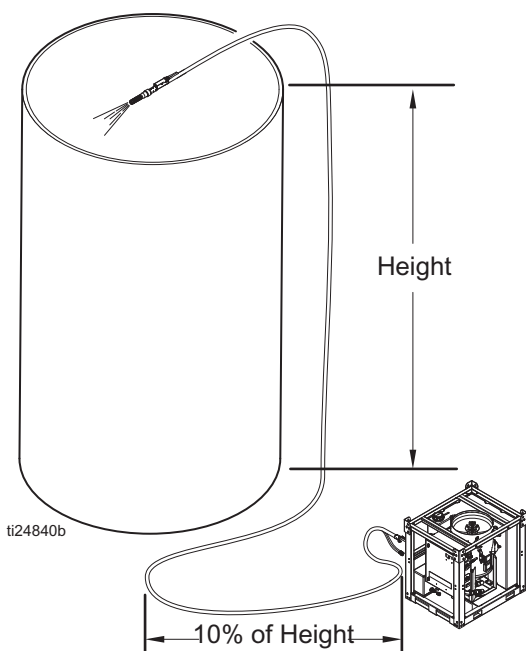

Pinch Hose Inspection

Inspect the pinch hose at the start of each job looking for “bubbles” in the outer casing. If bubbles in the casing are found, replace the pinch hose (see **Replace the Pinch Hose**, page 37). Keep a spare pinch hose on the job site in case of failure. See **Vapor Abrasive Blast Systems and Accessories**, page 56.

NOTE: There are three main factors that can affect (diminish) the life of the pinch hose: abrasive media used (course/sharp), blast control switch trigger rate (high), and the air inlet pressure to the system (high). If your setup reflects one or more of these factors, inspect the pinch hose at the start of each job, and weekly thereafter for signs of failure (bubbling).

Connect the Blast Hose and Air Hose



1. **ATEX models only:** Connect the grounding cable to the external ground stud on the enclosure, then connect the clamp to a true earth ground.

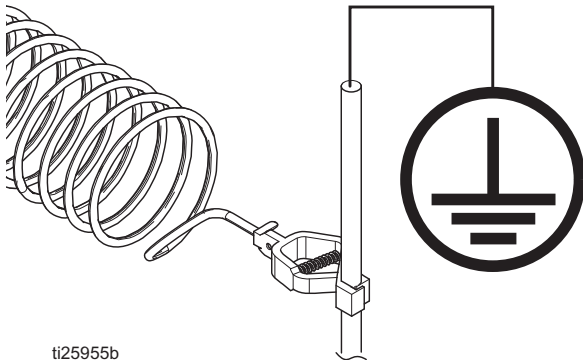

ti25955b

2. Always purge the air supply hose for 15-20 seconds before connecting the air supply hose from the compressor (or on-site compressed air source) to the panel. Make sure all debris is cleared from the hose.

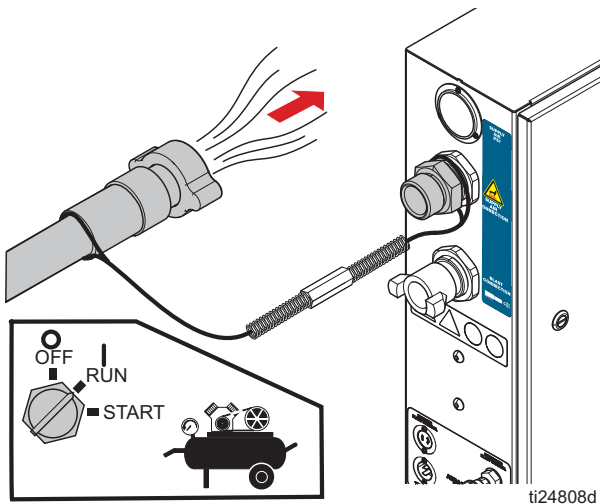

ti24808d

3. Connect an appropriately sized air supply hose to the air inlet and install coupler pins. See **Technical Specifications**, page 64.

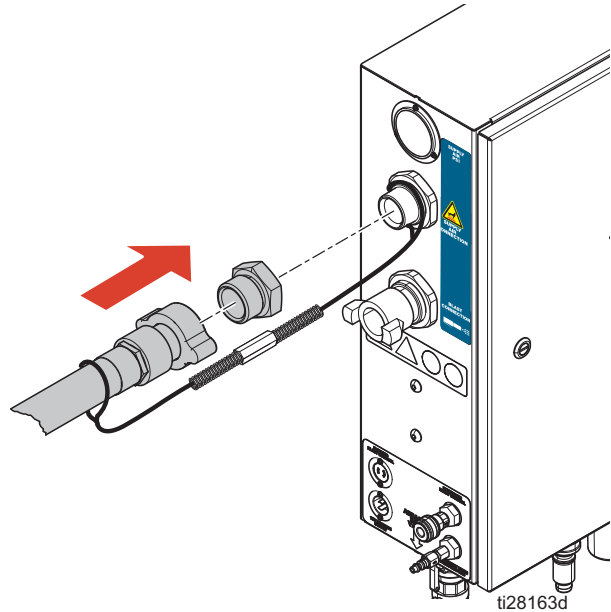

ti28163d

NOTICE

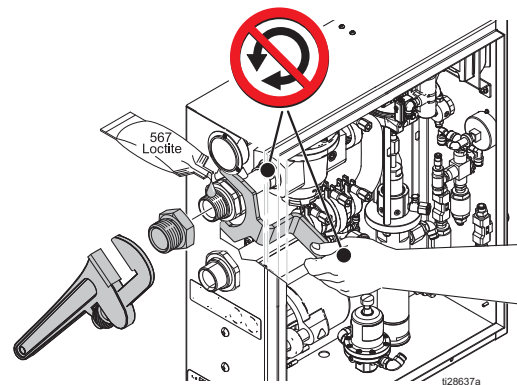

Damage to the tubing connections on the blast control can occur if the blast circuit is allowed to rotate. To avoid damage, use the supplied wrench to hold the blast circuit nut inside the enclosure while installing fittings to the air inlet and blast hose connections.



ti28637a

4. Open the compressor air supply valve (175 psi, 12.06 Bar, 1.2 MPa maximum compressor supply).

NOTE: Make sure the air supply meets the appropriate air flow requirements. See **Technical Specifications**, page 64.

				
<p>Failure to fully secure the blast hoses may cause hoses to detach during operation. To help prevent serious injury from flying debris, always install the blast hose restraints and coupler pins.</p>				

5. Connect the blast hose, hose restraints, control hoses, and coupler pins.

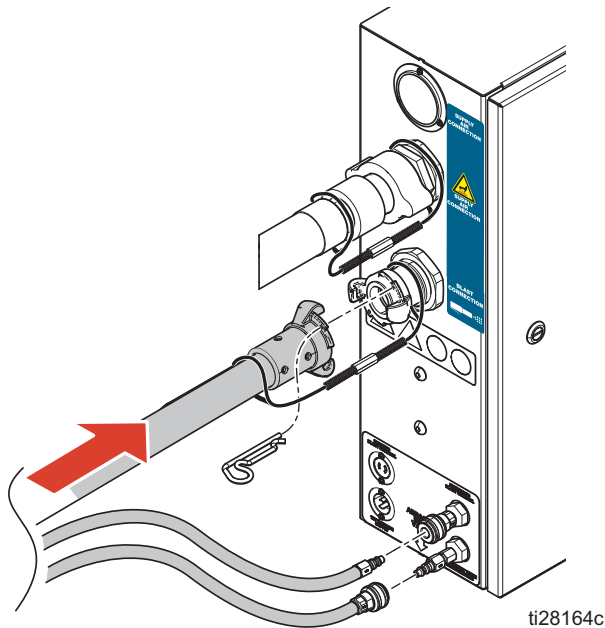

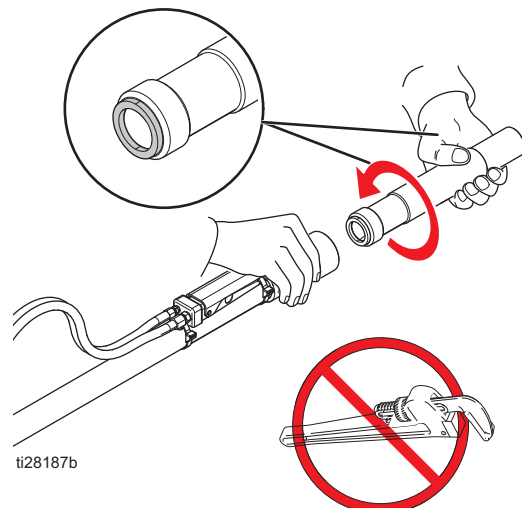
NOTICE	
<p>Do not use a wrench when installing the nozzle. Damage to the seal could occur. To avoid seal damage, always hand-tighten the nozzle.</p>	
	
<p>ti28187b</p>	

Connect the Water Supply

				
---	---	--	--	--

NOTE: Only connect the water hose for EQc systems.

Connect to a water supply hose with a minimum ID of 3/4 in. (19 mm) to the garden hose connection on the pump inlet.

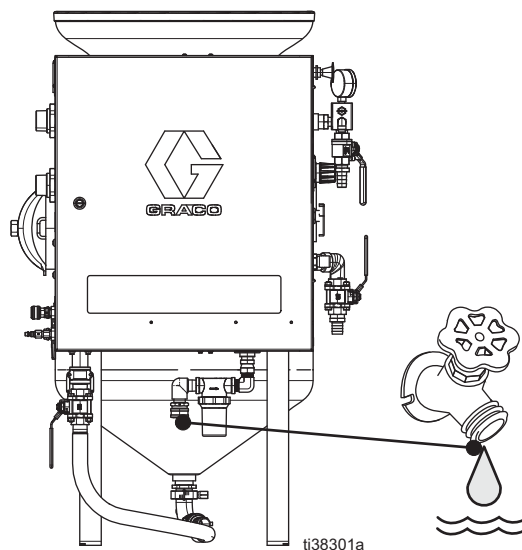

NOTE: The maximum water supply pressure is 100 psi (6.8 bar, 0.68 MPa). The minimum flow requirements is 3 gpm (11 lpm).

Setup

Fill the Water Tank



1. Fill the water tank with fresh water only, then open the inlet ball valve (N).

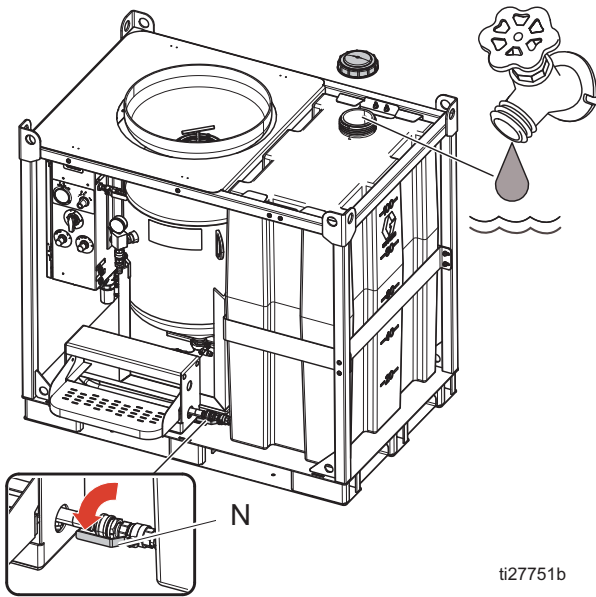

ti27751b

2. Close the rinse ball valve (X) and abrasive ball valve (M).

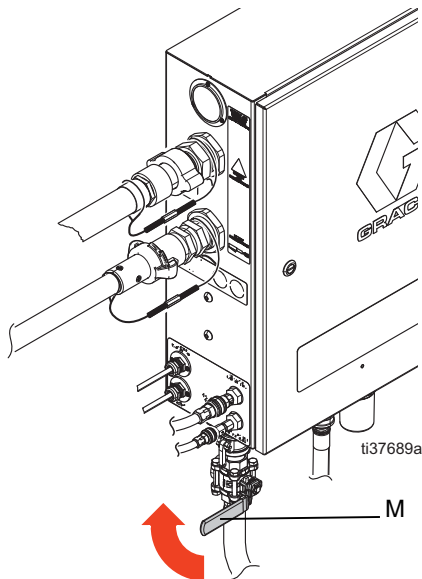

ti37689a

3. Turn the selector valve to OFF.



ti27756a

4. Disengage the emergency stop (Q).

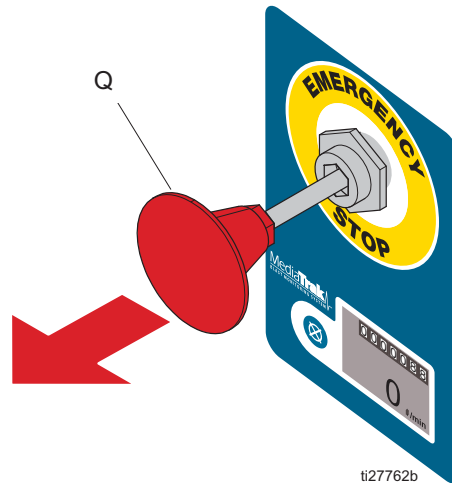

ti27762b

NOTE: The water pump will not work unless the Emergency Stop is disengaged.

Fill Pot with Abrasive Media



1. Verify that the pot seal plunger (F) is in the DOWN position. If the plunger is in the up position, perform the **Pressure Relief Procedure** procedure, page 19.
2. Verify that **Installation**, page 12, is complete.
3. Close the rinse ball valve (X) and the abrasive ball valve (M).
4. Turn the selector valve (W) to OFF.



FIG. 1: Turn the Selector Valve Off

5. Open the pot dump valve (J).

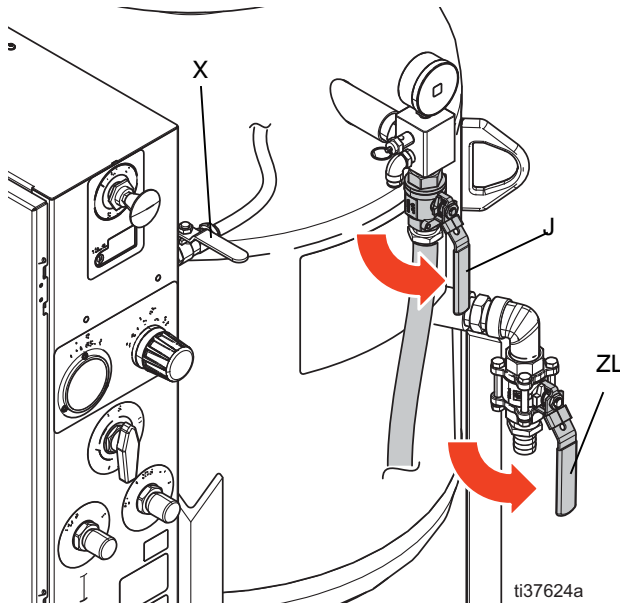

FIG. 2: Open the Pot Dump Valve

6. Open the quick drain valve (ZL).

7. Prepare the pot to accept media:
 - **To fill an empty pot:** Fill approximately half the pot (E) with water, until the water drains from the quick drain valve (ZL). Shut the quick drain valve.
 - **To refill the pot during operation:** open the quick drain valve (ZL) to drain the water until the pot is approximately half full. Shut the quick drain valve.

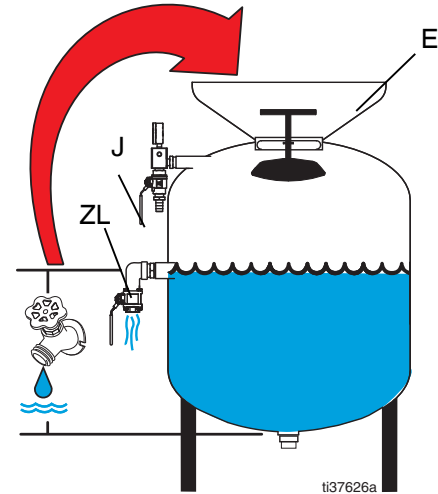

FIG. 3: Fill the Pot

8. Add abrasive media to the pot.

NOTE: The media level should be a few inches below the pot seal plunger (F). Do not overfill the pot with abrasive material, or the pot seal plunger will not be able to seal.

NOTE: As long as the abrasive media is below the plunger, the water level can rise above the pot seal plunger (F) without affecting performance.

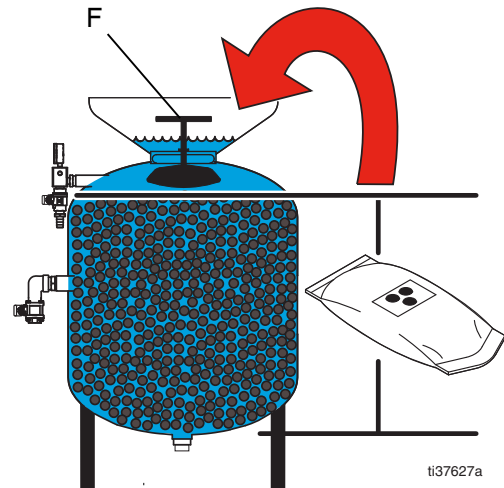





FIG. 4: Add Abrasive Media

Setup

9. **For systems with water tank only:** If the water tank (G) is less than halfway full, fill the tank with fresh water.
10. With a garden hose or the rinse valve (X), wash the abrasive into the pot and clear any abrasive from the pot seal plunger (F) and pot seal plunger gasket.
11. Close the pot dump valve (J).
12. Fill the pot with water until the water level is above the pot seal plunger (F).

Pressurize the Pot

				
To avoid injury to the operator, always pressurize the pot before opening the abrasive ball valve (M) or engaging the blast control switch (B).				

1. Verify that the pot seal plunger (F) is in the down position and the top of the plunger is clean of abrasive media.
2. Verify that the rinse ball valve (X), abrasive ball valve (M), the pot dump valve (J), and the quick drain valve (ZL) are all shut.
3. Verify that the water level in the pot (E) is above the pot seal plunger (F).
4. Turn the selector valve (W) to BLAST.

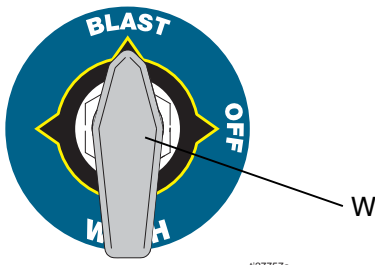

FIG. 5: Turn the Selector Valve to Blast

5. Pull upwards on the pot seal plunger (F). Hold until the pot pressure on the pot pressure gauge (L) rises to 185 psi. The pressure holds the pot seal plunger in place.

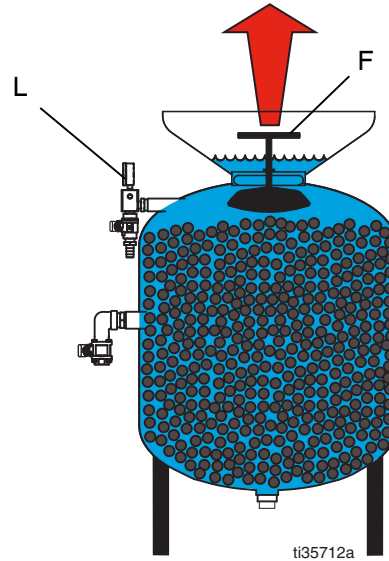

FIG. 6: Add Abrasive Media

6. Verify that the pressure on the pot pressure gauge (L) has risen above 170 psi.

Operation

				
---	---	---	---	--

This equipment may introduce dust and debris into the air. To help prevent serious injury from flying debris, always wear personal protective equipment while operating the equipment.

Pressure Relief Procedure



Follow the Pressure Relief Procedure whenever you see this symbol.

				
---	---	---	---	--

This equipment stays pressurized until pressure is manually relieved. To help prevent serious injury from pressurized fluid such as splashing fluid, follow the Pressure Relief Procedure when instructed.

1. Close the abrasive ball valve (M).

NOTE: If the abrasive ball valve is not closed when the supply air is shut off, gravity will cause abrasive media and water to drain from the pot (E) into the blast hose (C).

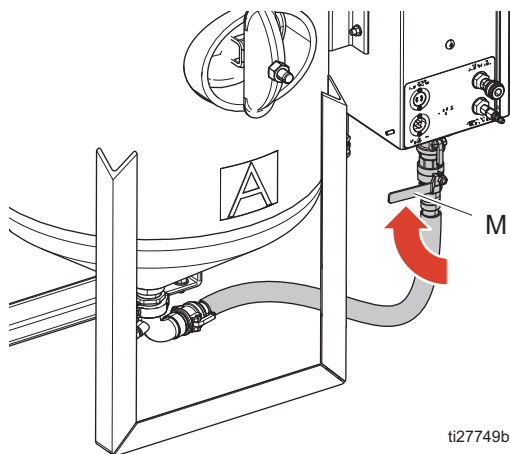

2. Close the compressor supply air valve, then turn the compressor off.
3. Engage the emergency stop (Q).
4. Engage the blast control switch (B) to relieve pressure in the system.

5. Verify that the supply pressure gauge (ZC) reads 0 psi. Then disconnect the air inlet hose from the system.

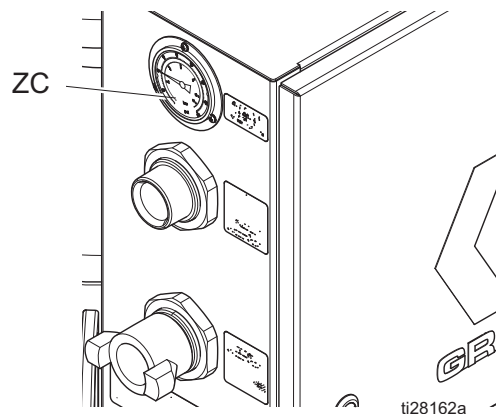

6. Turn the selector valve (W) to BLAST.

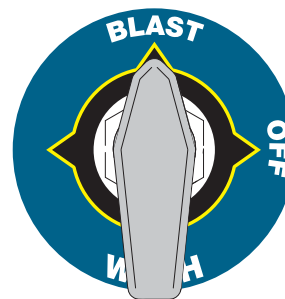

7. Open the pot dump valve (J) until the pot pressure gauge (L) reads 0 psi.

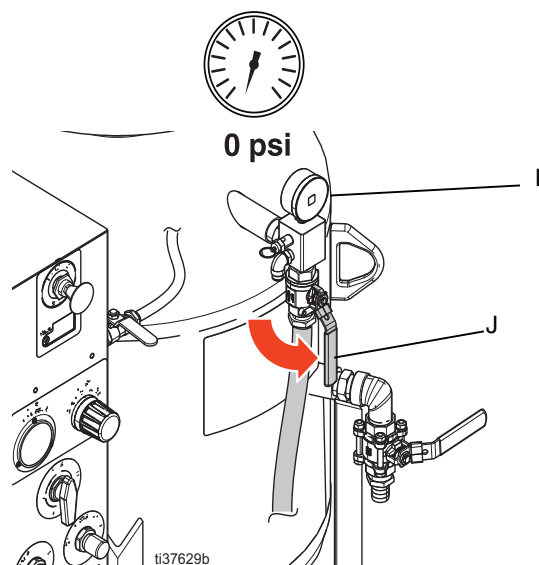

8. Close the pot dump valve (J), Turn the selector valve (W) to OFF.

Adjust Blast Pressure



To avoid injury due to a spray from wet media from the pot, always **Pressurize the Pot** before opening the abrasive ball valves (M) and engaging the blast control switch (B).

1. Perform the **Fill Pot with Abrasive Media** procedure, page 17.
2. Perform the **Pressurize the Pot** procedure, page 18.
3. Trigger the blast control switch (B).

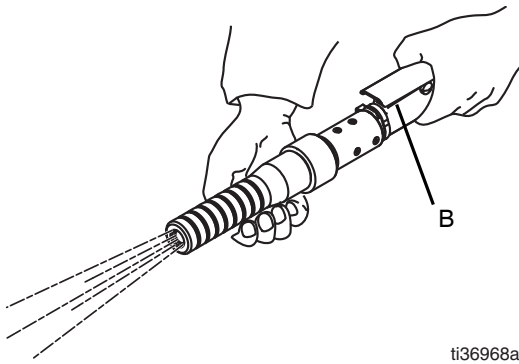

4. Adjust the blast air regulator (R) until the desired pressure appears on the blast pressure gauge (V).

NOTE: Do not increase directly to blast pressure. Always set below the desired pressure, then increase to the actual setpoint.

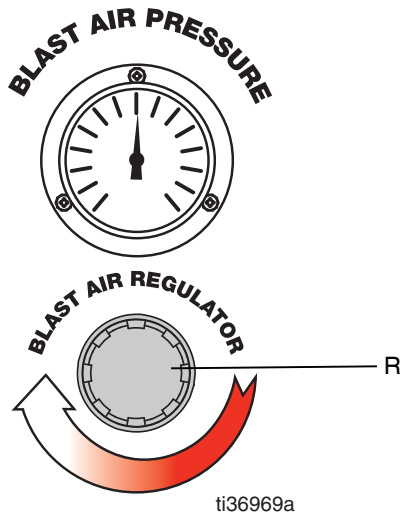

5. Disengage the blast control switch (B).

Adjust Abrasive Media

1. Perform the **Adjust Blast Pressure** procedure, page 20.
2. Open the abrasive media ball valve (M). Trigger the blast control switch (B).

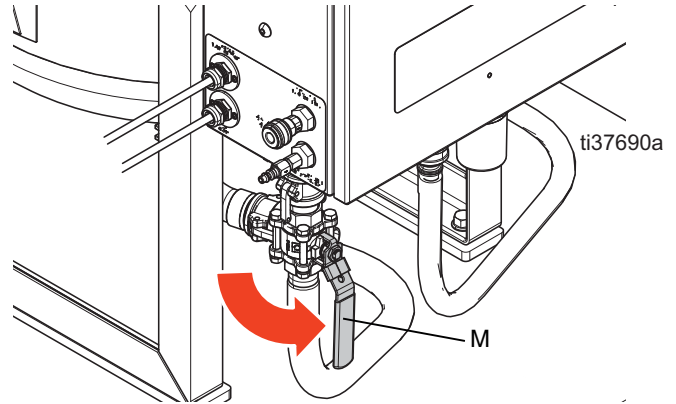

3. Turn on the MediaTrak display (PK).
4. Slowly adjust the abrasive metering valve (T) to the desired flow of abrasive media.

NOTE: You may have to wait 1-2 minutes for the abrasive material to reach the nozzle.

NOTE: Use a piece of test material similar to what you will be blasting. Always start as gently as possible and then increase the blast force as necessary to clean without doing any damage to the substrate.

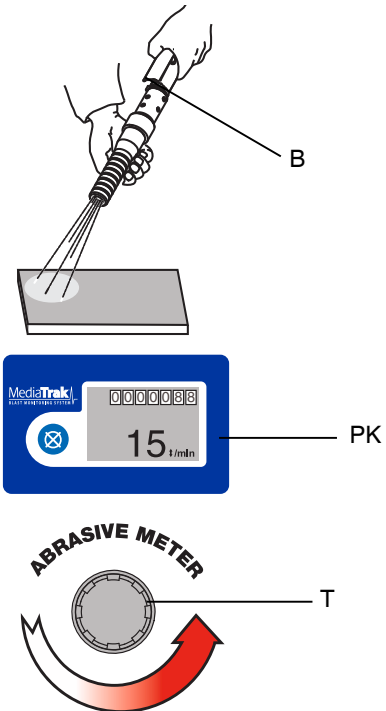

Refill Pot with Media

As abrasive media leaves the pot during blasting, follow the **Fill Pot with Abrasive Media** procedure, page 17.

NOTE: If the pot loses pressure, follow the **Pressurize the Pot** procedure, page, 18.

Set the Abrasive Metering Value

The optimal setpoint of the abrasive metering valve and corresponding MediaTrak CPM (cycles per minute) value varies significantly depending on application and user desired performance. The **General Application Guides**, page 22, describe the generally accepted range of CPM setpoints based on the substrate and blast pressure setpoint. The gray highlighted area illustrates the typical range of blast pressure setpoints and their corresponding CPM setpoints for that substrate.

To find the recommended CPM setpoint, select the table that most closely matches the substrate that is to be blasted. Determine the blast pressure setpoint based on the media that is being used, and the desired surface profile to be achieved. Then, use the corresponding lines on the chart to select the appropriate CPM setpoint.

For inexperienced users, select a blast pressure near the low end of the highlighted range. Increase blast pressure and CPM until the desired profile and removal rate are achieved.

Optimize the Abrasive Metering Value

To optimize performance, use the High Production or Media Efficient lines on the charts. CPM setpoints near the High Production lines will yield the highest removal rates, and the highest media consumption rates. To maximize removal rate regardless of media consumption, use the highest possible blast pressure and set the CPM to the highest achievable value that produces a consistent pattern. The CPM setpoint is too high if the flow from the nozzle starts to sputter.

CPM setpoints near the Media Efficient line will use the lowest amount of media. To minimize cleanup and media usage, use a setpoint closer to this line. Generally, removal rates will be less than average when setting the CPM according to this line.

The charts on the following page are only guidelines. They were developed using garnet media in the 30-80 mesh range. Coarser media will produce a deeper profile, but will require higher CPM setpoints to yield similar removal rates to the setpoints shown in the tables. Finer media will yield higher removal rates, but will not produce as deep of a profile.

Fine tuning and experimentation are necessary to optimize performance for each application.

See the **General Application Guides**, page 22.

General Application Guides

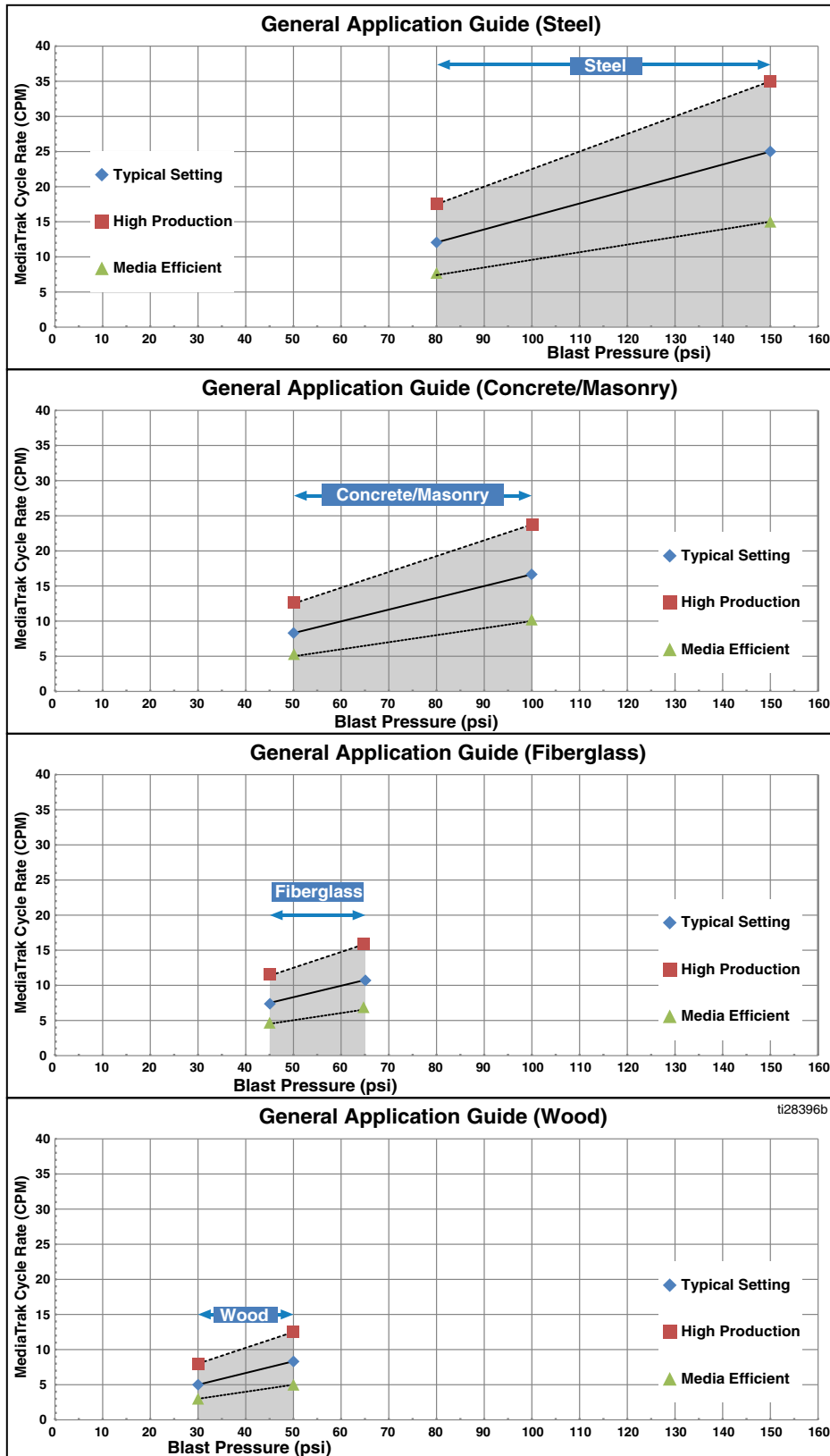

Nozzle Selection Guide

Use the **Blast Pressure vs. Air Flow Guide** to determine which nozzle to use to achieve the desired blast pressure based on compressor output.

Blast Pressure vs. Air Flow Guide

Blast Pressure	#6HP CFM (m ³ /min)	#7 CFM (m ³ /min)	#7HP CFM (m ³ /min)	#8 CFM (m ³ /min)	#8HP CFM (m ³ /min)	#10 CFM (m ³ /min)	#10HP CFM (m ³ /min)
30 psi (2.0 bar, 0.20 MPa)	78 (2.2)	117 (3.3)	137 (3.9)	151 (4.3)	161 (4.6)	229 (6.5)	224 (6.9)
40 psi (2.8 bar, 0.28 MPa)	90 (2.5)	129 (3.7)	161 (4.6)	181 (5.1)	212 (6.0)	254 (7.2)	286 (8.1)
50 psi (3.5 bar, 0.35 MPa)	117 (3.3)	161 (4.6)	193 (5.5)	200 (5.7)	225 (6.4)	308 (8.7)	337 (9.5)
60 psi (4.1 bar, 0.41 MPa)	137 (3.9)	190 (5.4)	225 (6.4)	234 (6.6)	256 (7.2)	362 (10.3)	391 (11.1)
70 psi (4.8 bar, 0.48 MPa)	166 (4.7)	225 (6.4)	251 (7.1)	269 (7.6)	293 (8.3)	422 (11.9)	447 (12.7)
80 psi (5.5 bar, 0.55 MPa)	188 (5.3)	244 (6.9)	281 (8.0)	298 (8.3)	337 (9.5)	460 (13.0)	498 (14.1)
90 psi (6.2 bar, 0.62 MPa)	210 (5.9)	266 (7.5)	293 (8.3)	317 (9.0)	374 (10.6)	520 (14.7)	562 (16.0)
100 psi (6.9 bar, 0.69 MPa)	239 (6.8)	283 (8.0)	327 (9.3)	378 (10.7)	413 (11.7)	561 (15.9)	601 (17.0)
110 psi (7.6 bar, 0.76 MPa)	256 (7.2)	325 (9.2)	347 (9.8)	420 (11.9)	457 (12.9)	634 (18.0)	664 (18.8)
120 psi (8.3 bar, 0.83 MPa)	273 (7.7)	344 (9.7)	378 (10.7)	452 (12.8)	476 (13.5)	691 (19.6)	720 (20.4)
130 psi (9.0 bar, 0.90 MPa)	288 (8.2)	374 (10.6)	415 (11.8)	493 (14.0)	527 (16.2)	721 (20.4)	759 (21.5)
140 psi (9.7 bar, 0.97 MPa)	313 (8.9)	405 (11.5)	449 (12.7)	530 (15.0)	571 (16.2)	758 (21.5)	797 (22.6)
150 psi (10.3 bar, 1.0 MPa)	331 (9.5)	430 (12.2)	476 (13.5)	558 (15.8)	601 (17.0)	796 (22.54)	853 (24.2)

Legend:

< 185 CFM

185 - 375 CFM

> 375 CFM

Use the Wash Feature



The wash feature uses water (without abrasive) to rinse areas that have been blasted with abrasive. It is also a convenient feature for flushing abrasive from the blast hose.

NOTICE

There will always be some residual abrasive in the blast hose. Never use the wash feature on any surface other than where you have blasted, or intend to blast. It will affect/dull the surface.

NOTICE

Do not use the wash feature on wood that has been blasted. It could damage the wood and cause the grain to rise. Wait for the wood to dry and then use a broom, brush, or vacuum to remove any residual abrasive.

1. Close the abrasive ball valve (M).

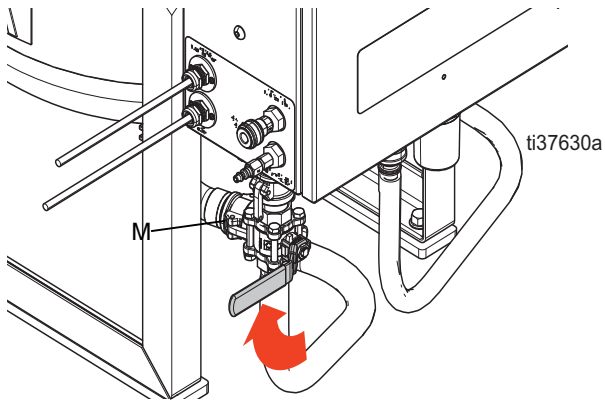

2. Turn the selector valve to WASH.

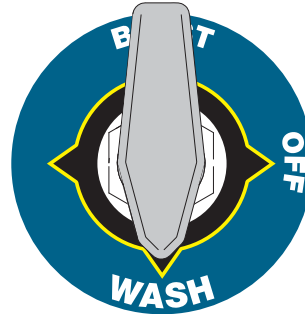

3. Blast 1-2 minutes until the abrasive is cleared from the hose.

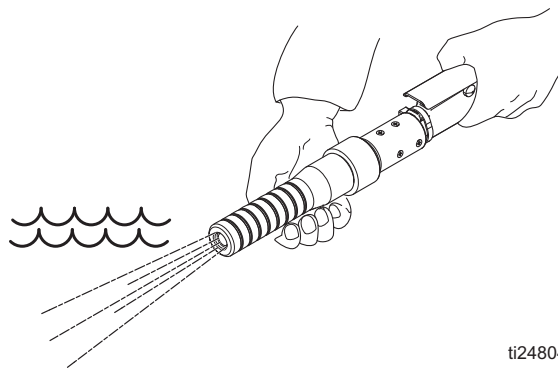

4. The equipment is now ready to wash any previously blasted surfaces.

Standby

1. Close the abrasive ball valve (M).

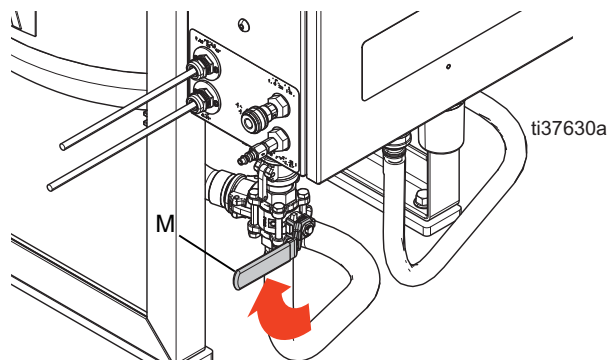

NOTICE

To prevent material from packing out and damaging the blast hoses, do not shut off your air compressor during Standby.

2. Turn the selector valve (W) to OFF.



3. Open the pot dump valve (J) until the pot pressure gauge reaches 0 psi.

POT PRESSURE

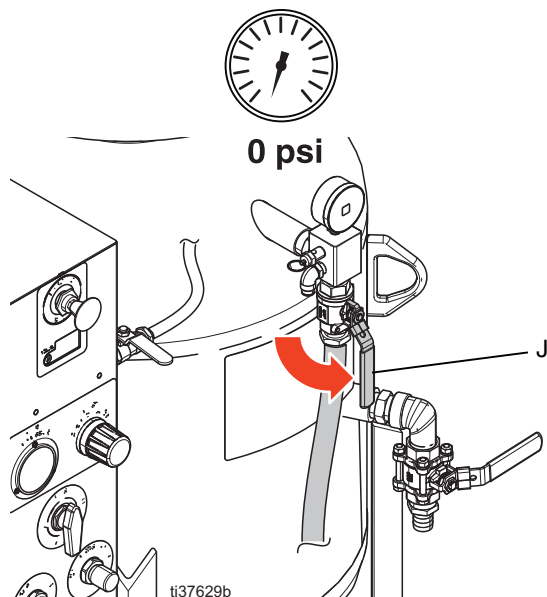

Shutdown



NOTICE

To prevent material from packing out and damaging blast hose, ensure that the abrasive ball valve is fully closed before shutting off your air compressor.

1. When you have finished blasting, use the wash feature to flush all abrasive from the blast hose. See **Use the Wash Feature**, page 24.
2. Turn the selector valve to OFF, and with the abrasive ball valve closed, continue to blast until water is cleared from the hose. This is to dry the inside of the hose for storage.



3. Perform the **Pressure Relief Procedure** procedure, page 19.

Drain the Pot

1. Before draining the pot (E), verify that the **Pressurize the Pot** procedure has been completed (see page 18). Check the pot pressure gauge (L) to verify that the pot is pressurized.
2. Close the abrasive ball valve (M).

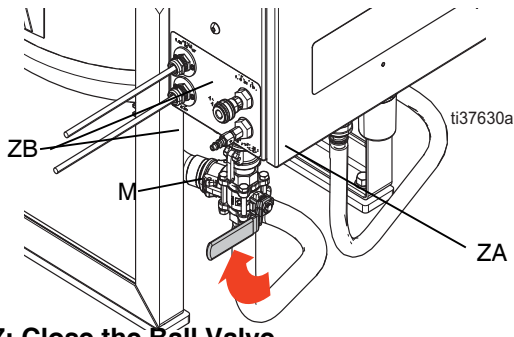

FIG. 7: Close the Ball Valve

3. Disconnect the blast control connections (ZA, ZB).
4. Disconnect the camlocks between the enclosure and the abrasive ball valve (M).
 - a. Remove the coupler pins.
 - b. Pull the rings out and up to pull the two cams away from the groove.

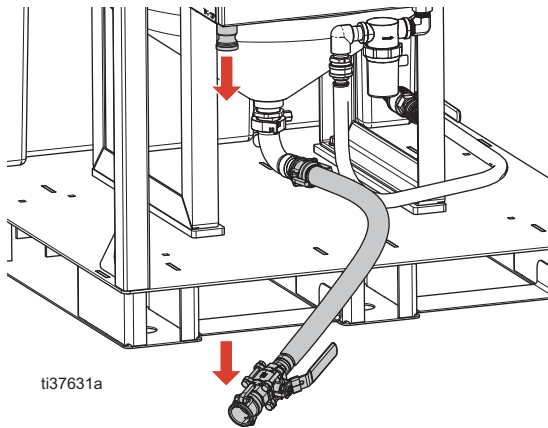

FIG. 8: Disconnect the Camlock

5. Place a bucket under the camlock coupler.
6. Turn the selector valve (W) to WASH to run water through the camlock coupler and gasket.
7. Verify that the gasket is clean and fully installed.
8. Turn the selector valve (W) to BLAST to pump abrasive out of the abrasive hose.
9. Place a bucket under the end of abrasive hose.
10. To flush abrasive material from the pot, slowly open and close the abrasive ball valve (M). Repeat several times.
11. Once no abrasive material flows from the hose, close the abrasive ball valve (M)
12. Turn the selector valve (W) to OFF.
13. Open the abrasive ball valve (M) and drain the water from the pot.
14. Shut the abrasive ball valve (M).
15. Connect the camlock between the enclosure (1) and the abrasive ball valve (M).

Winterize the Equipment



NOTICE

Vapor abrasive blasters must be winterized to avoid damage to the equipment whenever there is a possibility of freezing temperatures during storage.

1. Drain the pot. Perform the **Drain the Pot** procedure, page 26.
2. Drain the water tank by disconnecting the pump inlet hose and opening the inlet ball valve (N).
NOTE: All disposals must comply with national, state, and local regulations.
3. Drain the pump inlet hose, then insert the end into a windshield wash container. Choose a windshield wash with a rating that will protect the equipment for the lowest temperatures in your area.

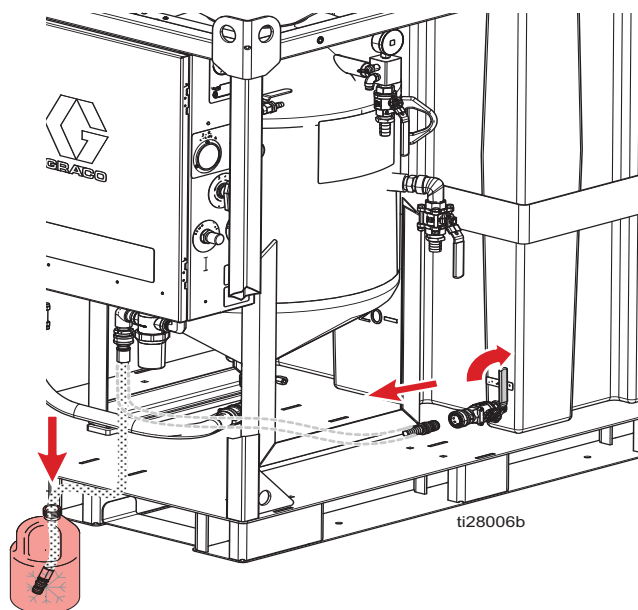

4. Turn the selector valve to WASH and open the rinse ball valve. While holding the rinse hose over the pot, run the pump until windshield wash comes out of the rinse hose.



ti27758a

5. Move the selector valve into the other two positions (BLAST and OFF). Confirm that the internal water tubing fills with windshield wash before turning the selector valve to the next position.
NOTE: All water tubing should be filled with windshield wash for full protection.
6. Engage the emergency stop (Q).
7. Reconnect the pump inlet hose to the inlet ball valve (N).
8. Make sure that the rinse ball valve (X) and the inlet ball valve (N) are left open.

NOTICE

When ice forms behind the seals, the seals can become damaged. During storage, position all ball valves in the open position.

Clean the Water Tank



1. Perform the **Pressure Relief Procedure** procedure, page 19.
2. Disconnect the water inlet hose.

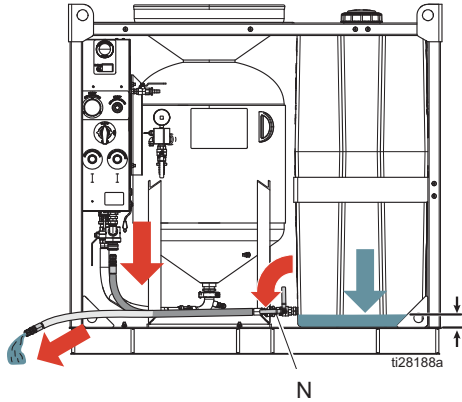

3. Open the inlet ball valve (N) and drain.
4. Remove the tank drain.

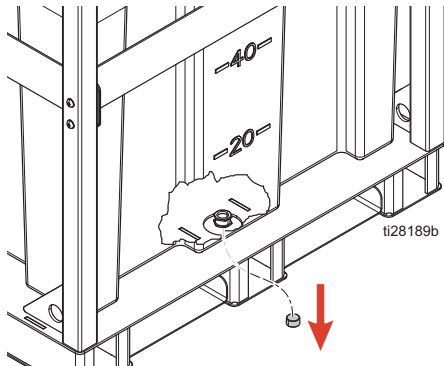

5. Remove the tank lid and clean out with pressure washer.

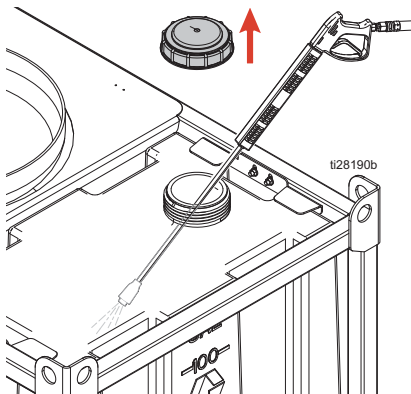

Use the Water Dose Meter



The water dose meter is a feature that allows the user to adjust how wet the blast will be during operation.

1. Perform the **Adjust Abrasive Media** procedure, page 20.
2. Adjust the water dose valve (S) to adjust how wet the blast will be during operation.

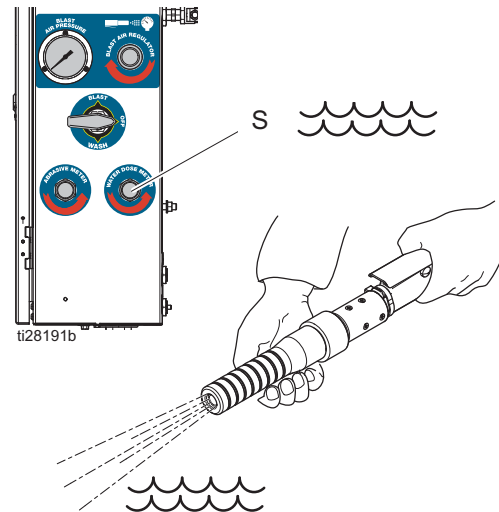

Troubleshooting



Problem	Cause	Solution
Unable to fill or pressurize the pot with water.	The emergency stop (Q) is engaged.	Disengage the emergency stop (Q).
	The air supply is inadequate.	Make sure the air compressor is capable of supplying the minimum air flow requirements for your system. See Technical Specifications , page 64. Make sure the air inlet pressure gauge reads 100-175 psi (6.8-12 bar, 0.68-1.2 MPa). If the gauge does not read 100-175 psi, check the air compressor for proper setup. Make sure the air inlet filters are clean, and replace if necessary.
	Inadequate water supply to the pump.	Systems with water tanks: Make sure the water tank is full and the inlet ball valve is open. Clean or replace water inlet filter if necessary. Make sure all fittings connections are tight.
		Systems with pressurized supply connections: Ensure water supply connection is connected and pressurized. Check that water supply meets appropriate pressure and flow requirements. Ensure all fitting connections are tight. Check inlet water pressure regulator for proper flow direction installation. Check inlet water pressure regulator screen filter for debris, clean if possible. Replace regulator if no flow can be passed through regulator.
	The water pump air regulator is malfunctioning.	Disengage the blast control switch (B). Adjust the pump inlet air pressure regulator until the pump air pressure regulator gauge reads 100 psi (6.9 bar, 0.69 MPa). If you are unable to attain this setting, check the air inlet filters and make sure the supply air pressure is greater than or equal to 100 psi. If the above steps do not resolve issue, replace the pump air pressure regulator.
	The water pump is malfunctioning.	Rotate 3-way selector valve to OFF position. Open rinse valve and ensure pump cycles, and water flows from rinse hose. Close rinse valve and verify that pump stalls. If pump continues to creep or will not prime, refer to manual 333397 for pump service.
	The pot seal plunger cannot seal.	Make sure the pot seal plunger is clean and free of debris in the o-ring sealing area. Check for proper pot seal plunger alignment in the closed position (there should be no gaps between the o-ring and the pot seal plunger). Remove the o-ring and make sure the o-ring gland is clear of debris. Replace the o-ring and /or pot seal plunger if worn.
The water pressure regulator is malfunctioning.	Adjust the water pressure regulator until the pot pressure gauge reads 185 psi (12.75 bar, 1.275 MPa). If this adjustment is not possible, service the water pressure regulator. Refer to your regulator manual. See Related Manuals , page 3.	

Problem	Cause	Solution
<p>The blast hose recoils heavily when the blast control switch (B) is engaged. Large slugs of abrasive and water are ejected from nozzle.</p>	<p>The abrasive ball valve was left open during shut down.</p>	<p>See Shutdown, page 25, step 2.</p>
	<p>The abrasive ball valve is worn.</p>	<p>With the pot pressurized and the abrasive ball valve closed, engage the blast control switch (B) and check to make sure the pump is stalled. If the pump rod is creeping, replace the abrasive ball valve seals or the abrasive ball valve (M).</p>
	<p>The pinch hose is worn.</p>	<p>With the pot pressurized and the abrasive ball valve open, check to make sure the pump is stalled. If the pump rod is creeping, replace the pinch hose. See Replace the Pinch Hose, page 37.</p>
<p>The pot pressure relief valve is discharging water.</p>	<p>The water pressure regulator is malfunctioning.</p>	<p>Adjust the water pressure regulator to 185 psi (12.75 bar, 1.275 MPa). If this adjustment is not possible, service the water pressure regulator. Refer to your regulator manual. See Related Manuals, page 3.</p>
	<p>The pressure relief valve has failed.</p>	<p>Replace the pressure relief valve if weeping occurs at or below 185 psi (12.75 bar, 1.275 MPa).</p>
<p>No blast air flow when the blast control switch (B) is engaged. The water pump does cycle while the blast control switch is engaged.</p>	<p>The adjustable blast regulator is not adjusted to the correct pressure.</p>	<p>Adjust the blast regulator to the desired pressure while the blast control is engaged.</p>
	<p>The tubing to the main air regulator is not properly connected or there are air leaks in the fittings or tubing.</p>	<p>See the Tubing Schematic, page 59. Check for leaks at connection points.</p>
	<p>The adjustable blast air regulator is malfunctioning.</p>	<p>Clean or replace the adjustable blast air regulator.</p>
	<p>The main air regulator is malfunctioning.</p>	<p>Disassemble the main air regulator and inspect components. Replace or repair parts as necessary. See Enclosure Box Parts, page 48.</p>

Problem	Cause	Solution
<p>No blast air flow when the blast control switch (B) is engaged. The water pump does not cycle while the blast control switch is engaged.</p>	<p>The emergency stop (Q) is engaged.</p>	<p>Disengage the emergency stop (Q).</p>
	<p>The air supply is inadequate.</p>	<p>Make sure the air compressor is capable of supplying the minimum air flow requirements for your system. See Technical Specifications, page 64, for more information. Make sure the air inlet pressure gauge reads 100-175 psi (6.8-12 bar, 0.68-1.2 MPa). If the gauge does not read 100-175 psi, check the air compressor for proper setup.</p>
	<p>The electric blast control circuit is malfunctioning.</p>	<p>Ensure proper 12V DC supply is connected, and at full charge. Inspect cable for damaged or 'open' wiring. Check blast control fuse and replace if necessary. Check for continuity through connectors on the control box and all external cables. Check continuity through the electric blast control switch (B) (the switch is normally open). If all above items are functional, replace the 4-way solenoid valve.</p>
	<p>The pneumatic blast control circuit is malfunctioning.</p>	<p>Actuate the blast control switch (B) and check for proper spool valve actuation in the 4-way valve. If no actuation occurs, check the blast control switch and twin-line by disconnecting the yellow tube at the enclosure male quick disconnect and engage the control switch. If no air comes from the fitting, check the pneumatic blast control filter. If the filter is clean, check for signal air at the blast control switch. Replace the pneumatic blast control switch if signal air does not pass through the valve when the handle is depressed. If the switch is functioning, make sure the yellow tubing inside the control box is properly connected and is clear of obstructions. If the tubing is clean, replace the 4-way solenoid valve.</p>



Problem	Cause	Solution
<p>While in BLAST mode, with the blast control switch (B) engaged, air is flowing from the nozzle but little or no abrasive is flowing from the nozzle.</p>	<p>The abrasive ball valve is closed.</p>	<p>See Connect the Water Supply, page 15.</p>
	<p>The abrasive metering valve is not properly set.</p>	<p>See Connect the Water Supply, page 15.</p>
	<p>The pot does not have a sufficient amount of abrasive.</p>	<p>See Refill Pot with Media, page 21.</p>
	<p>The pinch valve does not open.</p>	<p>Engage the blast control switch (B) and check for actuation of the pinch valve. If there is no actuation, disconnect the orange tubing at the pinch valve. If the pinch valve opens and source air is coming from the orange tubing, confirm that the tubing is correctly routed. If the pinch valve does not open, replace it. If the pinch valve opens and there is no source air coming from the tubing, inspect the mufflers on the 4-way valve for debris. If debris is not present, clean or replace the 4-way valve.</p>
	<p>There is an obstruction inside the pot or inside the abrasive hose between the pot and the enclosure.</p>	<p>Follow Drain the Pot, page 26, followed by the Installation, page 12. With the abrasive hose disconnected, inspect the interior of the pinch hose for obstructions or debris and replace if necessary (see Replace the Pinch Hose, page 37). Remove the tri-clamp from the bottom of the pot. Inspect the bottom of the pot and the abrasive hose for obstructions or debris.</p>
	<p>The pot pressure is too low.</p>	<p>With the blast control disengaged, allow the pot to pressurize and wait for the pump to stall. If the pot pressure gauge does not reach 185 psi (12.75 bar, 1.275 MPa), see the “Unable to fill or pressurize the pot with water” problem listed on this table.</p>
	<p>The blast pressure is too high.</p>	<p>If the blast pressure gauge reads 160 psi (11.03 bar, 1.10 MPa) or greater, it may not be possible to achieve than 15 CPM on the MediaTrak. This is more common with fine mesh abrasive usage. Decrease the blast pressure to 100 psi (6.9 bar, 0.69 MPa) to see if CMP can be increased.</p>

Problem	Cause	Solution
<p>The blast control switch (B) is not engaged, but blasting occurs.</p>	<p>The air supply is inadequate.</p>	<p>Make sure the air compressor is capable of supplying the minimum air flow requirements for your system. See Technical Specifications, page 64. Make sure the air inlet pressure gauge reads 100-175 psi (6,8-12 bar, 0.68-1.2 MPa). If the gauge does not read 100-175 psi, check the air compressor for proper setup.</p>
	<p>The main air regulator is malfunctioning or is stuck open.</p>	<p>Disassemble the main air regulator and check for obstructions. Replace or repair parts as necessary. See Enclosure Box Parts, page 48.</p>
	<p>The electric blast control circuit is malfunctioning.</p>	<p>Unplug the hose cable at the control box. If the blast stops, inspect the hose cable for shortened wiring. Check continuity through the electric blast control switch (B) (the switch is normally open). Check for continuity across connectors of the recessed plugs on the control box (there should be no continuity). If all above items are functional, replace the 4-way solenoid valve.</p>
	<p>The pneumatic blast control circuit is malfunctioning.</p>	<p>Engage the emergency stop (Q). If blasting stops, check the blast control switch (B) by disconnecting the yellow tube at the enclosure male quick disconnect. There should be no signal air unless you engage the control switch. If the switch is functioning, remove the exhaust mufflers from the 4-way and check for debris, clean ports, and replace the mufflers if necessary. If all above items are functional, replace the 4-way solenoid valve.</p>
<p>While the blast control switch (B) is engaged, the blast air flow is fluctuating.</p>	<p>The supply air pressure is fluctuating.</p>	<p>Make sure the compressor meets minimum flow requirements and is operating properly. See Technical Specifications, page 64, for more information on flow requirements.</p>
	<p>The main air regulator is malfunctioning or is stuck open.</p>	<p>Disassemble the main air regulator and check for obstructions. Replace or repair parts as necessary. See Enclosure Box Parts, page 48.</p>
	<p>The electric blast control circuit is malfunctioning.</p>	<p>Inspect the hose cable for damaged or shorted partially open wiring. Check the blast control fuse and replace if necessary. Check for loose wire connections on the recessed plugs on the control box (P) and all external cables. Check continuity through the electric blast control switch (B) (the switch is normally open). If all above items are functional, replace the 4-way solenoid valve.</p>
	<p>The pneumatic blast control circuit is malfunctioning.</p>	<p>Actuate the blast control switch (B) and check for proper spool valve actuation in the 4-way valve. If no actuation occurs, check the blast control switch by disconnecting the yellow tube at the enclosure male quick disconnect and engage the control switch. If only a little air comes from the fitting, check the twin-line hose for damage or crimping and check the pneumatic blast control filter. If the twin-line and filter are clean, replace the pneumatic blast control switch. If the switch is functioning, make sure the yellow tubing inside the control box is properly connected and clear any obstructions. If all above items are functional, replace the 4-way solenoid valve.</p>

Problem	Cause	Solution
The blast spray pattern is sputtering or irregular.	The air supply is inadequate.	Make sure the air compressor is capable of supplying the minimum air flow requirement for your system. See Technical Specifications , page 64. Make sure the air inlet pressure gauge reads 100-175 psi (6.8-12 bar, 0.68-1.2 MPa). If the gauge does not read 100-175 psi check the air compressor for proper setup. Make sure the air inlet filters are clean and replace if necessary.
	The blast hose was not properly cleaned out after previous use.	See Shutdown , page 25.
	The abrasive metering valve setting is too high for the blast pressure and/or abrasive type.	See Set the Abrasive Metering Value , page 21.
	The pot does not have a sufficient amount of abrasive.	Refill the pot with abrasive. See Refill Pot with Media , page 21.
	There is an obstruction in the nozzle.	Remove the nozzle and inspect for blockage, buildup, or damage. Replace the nozzle if necessary.
	There is an obstruction inside the pot or inside the abrasive hose between the pot and the enclosure.	Perform Drain the Pot , page 26, followed by Installation , page 12. With the abrasive hose disconnected, inspect the interior of the pinch hose for obstructions or debris and replace if necessary. See Replace the Pinch Hose , page 37. Remove the tri-clamp from the bottom of pot. Inspect the bottom of the pot and abrasive hose for obstructions or debris.
Too much dust occurs during blasting.	There is not enough water in abrasive mixture.	See Use the Water Dose Meter , page 28.
	The blast pressure is too high.	Decrease the blast pressure and re-evaluate the dust levels.
	The abrasive is too fine for the application.	Try a coarser or harder abrasive if possible.
Too much water is coming from the nozzle in BLAST mode.	The water dose valve (S) is open too far.	Close the water dose valve (S).
	The abrasive material is too coarse.	If possible, use at least 20 mesh abrasive material. Otherwise, decrease the CPM setpoint until the pattern improves.
	The abrasive metering valve setting is too high for blast pressure and/or abrasive type.	See Set the Abrasive Metering Value , page 21.

Repair

Replace the DataTrak Battery

				
<p>To reduce the risk of fire and explosion, the battery must be replaced in a non-hazardous location.</p> <p>Use only an approved replacement battery (see table). Use of an unapproved battery will void Graco's warranty.</p>				

Replace Battery

1. Unscrew cable from the back of the reed switch assembly.
2. Remove the cable from the two cable clips.

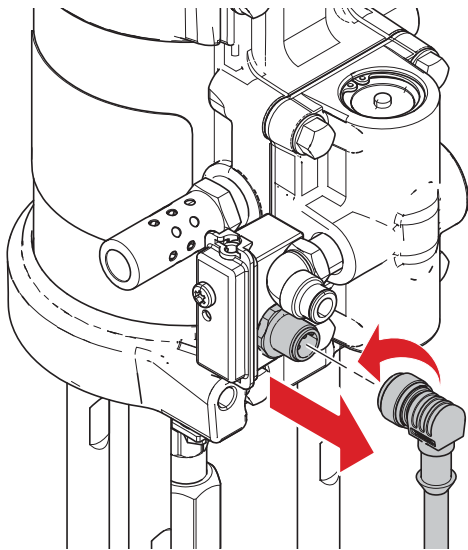

ti24946b

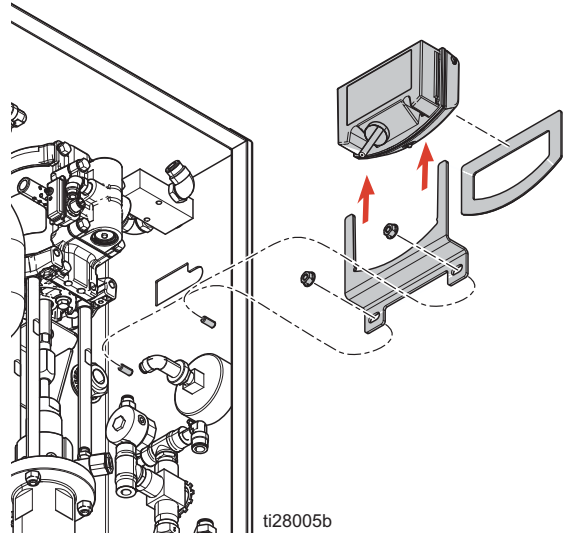

3. Remove the DataTrak module from the bracket. Take the module and attached cable to a non-hazardous location.



4. Remove the two screws on the back of the module to access the battery.
5. Disconnect the used battery and replace it with an approved battery.

Approved Batteries
Energizer® brand alkaline #522
Varta® brand alkaline #4922
UltraLife® brand lithium #U9VL
Duracell® brand alkaline #MN1604

Replace the DataTrak Fuse

				
<p>To reduce the risk of fire and explosion, the fuse must be replaced in a non-hazardous location.</p> <p>Use only an approved replacement fuse (see table). Use of an unapproved fuse will void Graco's warranty.</p>				

Replace Fuse

1. Remove the screw, metal strap, and plastic holder.
2. Pull the fuse away from the board.
3. Replace with an approved fuse.

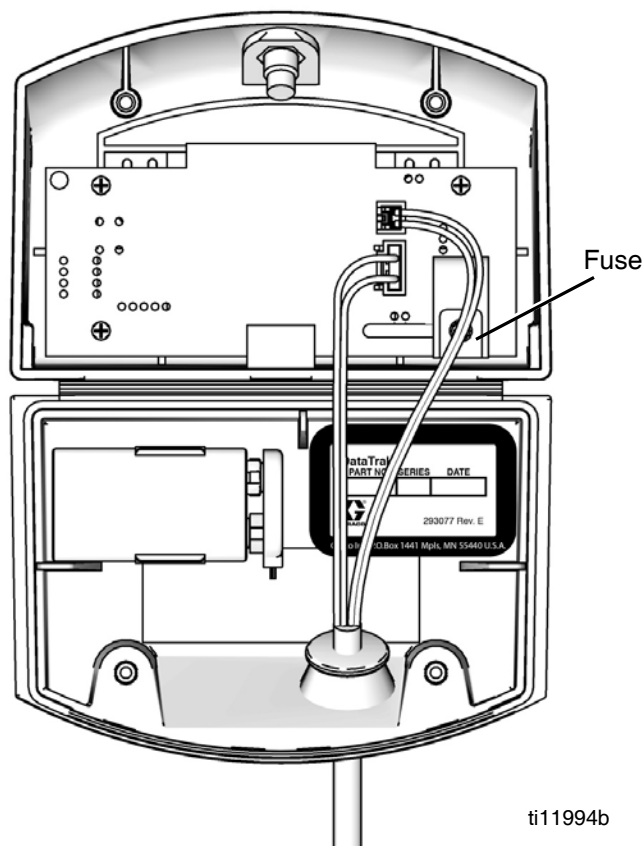

Approved Fuses		
DataTrak Part Number	Series Letter	Fuse Required
17K057	A or B	24C580
	C and later	24V216
All other part numbers	A	24C580
	B and later	24V216

Replace the Pinch Hose

Remove the Pinch Hose



1. Perform the **Pressure Relief Procedure** procedure, page 19.
2. Remove the claw coupler (CP) at the swivel connection.
3. Use the supplied 2-7/8 in. wrenches (WR) to loosen the lock nuts (S1, S2) on the inside and outside of the box.
4. Remove the clamp (HC) connecting the blast circuit (BC) to the check valve.
5. Remove check valve assembly (CV) and clean all abrasive that may be stuck to the check valve components.

NOTICE

Check valve components coated in abrasive can allow abrasive to enter the main air regulator and lead to improper operation. Clean off all abrasive material that may be stuck to the check valve components to allow for proper operation.

6. Remove the bottom hose clamp (C2).
7. Pull the pinch hose (PH) out of the box.
NOTE: Use the blast circuit (BC) as a handle, and twist while pulling.
8. Loosen the remaining hose clamp and remove the pinch hose from the circuit.

Install the Pinch Hose

1. Reinstall the check valve, ensuring proper orientation. Assemble the valve with the plunger facing the bent manifold.
2. Place both hose clamps (C1, C2) on the pinch hose (PH). Leave 1/4 in. of hose exposed on the ends.
3. Slide the pinch hose (PH) into the box through the pinch valve.
4. Reinstall the blast circuit (BC) and pinch hose (PH) into the box through the pinch valve.
5. Install and tighten the clamp (HC) to 15ft-lb (20.3 N•m) to connect the blast circuit to the check valve.
NOTE: If necessary, loosen the inside nut (S2) to provide room for gasket (G) installation. Inspect the gasket (G) and replace if necessary.
6. Apply anti-seize to threads on clamps (C1, C2). Align the nuts pointing towards the front of the enclosure. Torque to 85 +/- 5 in-lb (9.6 +/- 0.5 N•m).
7. Tighten the lock nuts (S1, S2).
8. Install the claw coupler (CP).

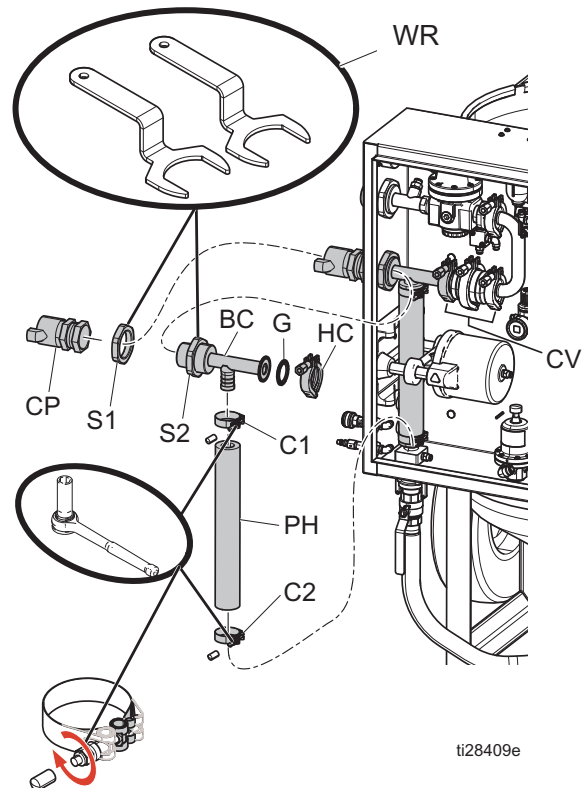

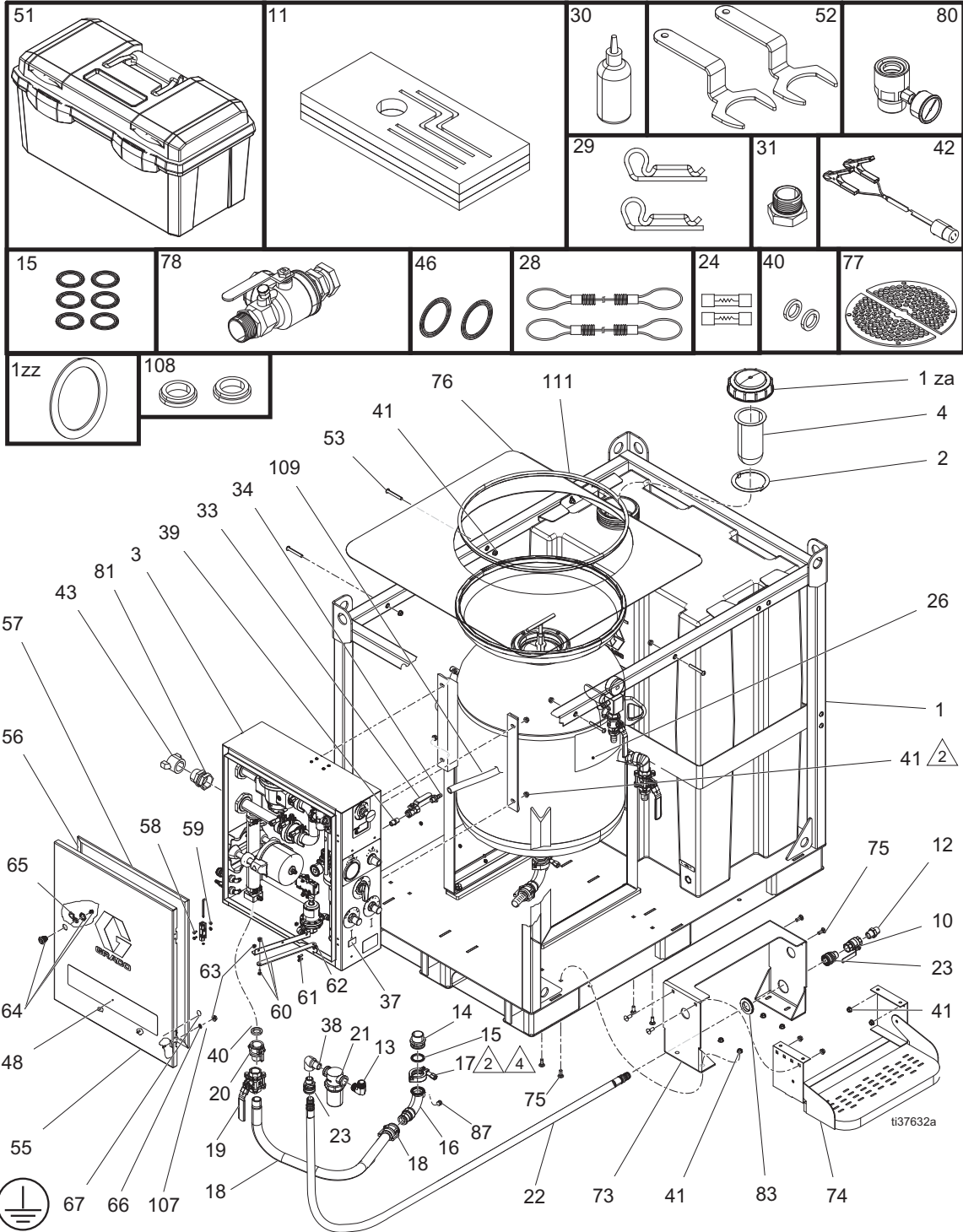

Parts

EQs Parts



1. Apply thread sealant to all non-swivel pipe threads.

 Apply anti-seize to threads.

 Torque to 15 +/- 2 ft-lb (20.3 +/- 2.7 N•m).

EQs Parts List

Ref.	Part	Description	Qty.	Ref.	Part	Description	Qty.
1	25P253	BASE, standard, frame, tank	1	53‡	-----	BOLT, button hd, 3/8-16 x 2.75	4
1za	EQ1907	CAP, vented, water tank, lid	1	55	25D032	DOOR, enclosure, lg	1
1zz	17D790	KIT, replacement, gasket, hand-way	1	56*	-----	GASKET, door, vertical	2
2	26A093	RING, adapter, filter (includes 5 filters)	1	57*	-----	GASKET, door, horizontal, large	2
3	-----	ENCLOSURE, EcoQuip; see Enclosure Box Parts , page 48	1	58	111639	SCREW, cap, hex hd	4
4	26A093	FILTER, element water tank	1	59	127918	NUT, flange, serrated, M5	4
10	129903	VALVE, ball, 3/4 npt, brass, nickel	1	60+	-----	DOOR, stay	1
11†	-----	INSERT, foam, tool box, EcoQuip,	1	61+	128666	SCREW, cap, button hd, (m)6 x 16, sst	2
12	190724	NIPPLE, sst	1	62+	15U698	NUT, hex, flange, serrated	2
13	17K344	FITTING, elbow, 3/4 npt, sst	1	63	127908+	NUT, flange, serrated, #10-32, ss	2
14	17H273	ADAPTER, tri-clamp, 1-1/4 npt, sst	1	63	127908*	NUT, flange, serrated, #10-32, ss	3
15	680454	GASKET, sanitary fitting	7	64	17L623	LOCK, door, tooled (includes 65)	1
16	17L631	MANIFOLD	1	65	-----	LATCH, cam, door lock	1
17	17L317	CLAMP, tri-clamp, 1.5 hex wing nut	1	66*	555629	WASHER, #10 external tooth lock	1
18	17L329	HOSE, inlet media (includes 40)	1	67*▲	186620	LABEL, symbol, ground	1
19!	17L046	VALVE, ball, 1 npt, SST	1	73**	-----	BRACKET, step	1
20	17J329	COUPLER, cam-lock, sst, 1 npt(f) (includes 40)	1	74**	-----	BRACKET, step, single, 20 in. wide	1
21	17L332	STRAINER, in-line	1	75**	-----	BOLT, carriage	8
22	17J795	HOSE, inlet, water	1	76‡	-----	COVER, media, fill	1
23	EQ1846	COUPLER, 3/4 pd(f), 3/4 npt(m)	2	77	-----	STRAINER, pressure pot	2
24❖	18A604	FUSE, glass, 0.25 x 1.25, 400 MA	2	78★	24Z005	KIT, accessory, air inlet, 1-1/2 npt	1
26#▲	3A7468	LABEL, instructions	1	80*	17J958	TOOL, pressure verification	1
28	17D789	KIT, replacement, whip check	2	81	113864	UNION, swivel, 1-1/2 npt	1
29	17D787	PIN, safety item, hose, hair c (6 pack)	2	83**	-----	GROMMET, pump, EQ2	1
30	206994	FLUID, TSL 8 oz. bottle	1	87	112306	PLUG, pipe, 3/8 npt, sst	1
31	EQ1829	FITTING, ground boss, spud, 1-1/2 in.	1	107*	194337	WIRE, grounding, door	1
33	17L642	VALVE, ball, 3/8 npt, sst	1	108	17C124	GASKET, metal blast coupler	2
34	EQ1627	FITTING, nipple, barb, hose, 3/8 in.	1	109	EQ1840	HOSE, braided, clear, 3/8 ID	6 ft
37	15Y118	LABEL, made in the USA	1	111‡	129210	TRIM, edge, neoprene, black	6.7 ft
38	115813	FITTING, street elbow, 3/4 npt	1	▲ <i>Replacement Danger and Warning labels are available at no cost.</i>			
39	167702	NIPPLE, pipe	1	★ <i>Elite models only.</i>			
40	17L309	GASKET, cam lock, buna, 1.0	2	❖ <i>Non-ATEX models only.</i>			
41‡**	128226	NUT, flange, 3/8-16, sst	4	* <i>ATEX models only.</i>			
42❖	EQ5183	CABLE, blast control switch, battery	1	# <i>Part included in 6.5 Cubic FT Pressure Pot Kit 17K046.</i>			
43	EQ1934	COUPLER, sandblast, 1-1/2 npt(f)	1	† <i>Part included in Replacement Tool Box Kit 24Z156.</i>			
46	502598	GASKET, sanitary (PTFE)	2	* <i>Part included in Large Door Gasket Kit 17L625.</i>			
48	-----	LABEL, brand, EcoQuip	1	+ <i>Part included in Door Stay Kit 17D686.</i>			
51†	-----	BOX, tool, 20 in., black	1	* <i>Part included in Pressure Verification Kit (purchase separately).</i>			
52	17L633	TOOL, EQ, wrench, 2-7/8	2	‡ <i>Part included in Bag Management Kit 17K026 (purchase separately).</i>			
				** <i>Part included in Step Accessory Kit 26A007 (purchase separately).</i>			
				! <i>See Common Spare Parts page 58, for ball valve seal repair kit.</i>			

EQs (continued)

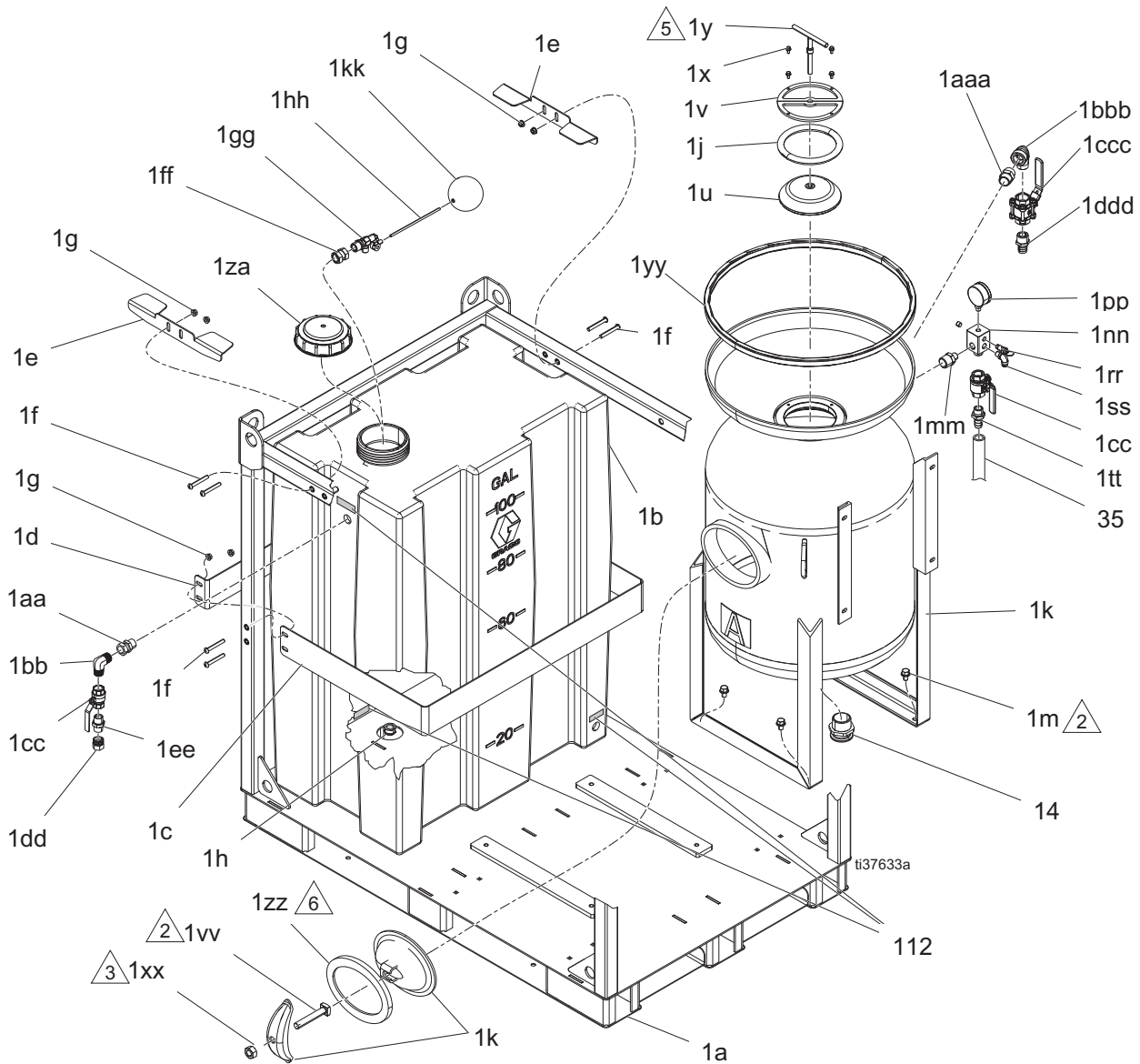

1. Apply thread sealant to all non-swivel pipe threads.

Apply anti-seize to threads.

Torque to 60 +/- 5 ft-lb (81.3 +/- 6.7 N•m) with pot pressurized.

Torque to 15 +/- 2 ft-lb (20.3 +/- 2.7 N•m).

Apply anti-seize to enclosure mounting studs.

The hand-way gasket must be assembled centered and flat on the hand-way cover.

EQs Parts List (continued)

Ref.	Part	Description	Qty.	Ref.	Part	Description	Qty.
1a	-----	FRAME, EcoQuip 2	1	1mm	17R930	FITTING, nipple, reducing, 1 x 1/2, sst	1
1b	17K048	TANK, EcoQuip 2, polyethylene	1	1nn	-----	MANIFOLD, dump	1
1c	17L636★	BRACKET, sst, tank, lg, EcoQuip 2	1	1pp	17L320	GAUGE, pressure, fluid	1
	17L639⊗	BRACKET, painted, tank, lg, EcoQuip 2	1	1rr	17L622	VALVE, safety relief, (220 psi)	1
1d	17L637★	BRACKET, sst, tank, small, EcoQuip 2	1	1ss	EQ1500	FITTING, elbow, swivel, male, 3/8 in.	1
	17L640⊗	BRACKET, painted, tank, small, EcoQuip 2	1	1tt	EQ1012	FITTING, nipple, barb, hose, 3/4 in.	1
1e	17L638★	BRACKET, sst, tank, clamp	2	1vv#	129057	BOLT, sq hd, 3/4 x 4-1/2, sst	1
	17L641⊗	BRACKET, painted, tank, clamp	2	1xx#	17K962	NUT, hex, 3/4-10, sst	1
1f	128818	BOLT, button hd, 3/8-16 x 2.75	8	1yy#	-----	TRIM, edge, neoprene, black	6 ft
1g	128226	NUT, flange, 3/8-16, sst	8	1za	EQ1907	CAP, vented, water tank, lid	1
1h	111384	PLUG, pipe	1	1zz#	17D790	GASKET, hand-way, 6 x 8	1
1j#	17L310	KIT, seal, o-ring, pressure pot	1	1aaa	EQ1612	FITTING, nipple, hex, 1 NPT	1
1k#	-----	PRESSURE POT, blast media, 6.5 cu ft	1	1bbb	EQ1578	FITTING, elbow, street, 1 NPT	1
1m	128819	BOLT, flange hd, serrated, 1/2, ss	4	1ccc!	17L046	VALVE, ball, 1 npt SST	1
1u#*	18A340PKG	PLUNGER, pot seal	1	1ddd	113607	FITTING, 1 in.. barb	1
1v#**	-----	BRACKET, d-ring, pop-up	2	14#	17H273	ADAPTER, tri-clamp, 1-1/4 npt, sst	1
1x#**	128504	BOLT, flange hd, serrated, 1/4 ss	4	35	EQ1360	HOSE, braided, clear, 3/4 ID	2
1y#*	18A383PKG	HANDLE, tee with stop	1	112	17J290	LABEL, instructions	1
1aa†	112268	SWIVEL, union	1				
1bb†	17K344	FITTING, elbow, 3/4 npt, sst	1				
1cc†	129903	VALVE, ball, 2 pc, SST, 3/4 npt	2				
1dd†	EQ7004	FITTING, hose, garden, 3/4 in. mpt x 3/4 in. fgt, swivel	1				
1ee†	190724	NIPPLE, sst	1				
1ff†	-----	FITTING, bushing	1				
1gg†	-----	VALVE, body, float, 1/2 npt	1				
1hh†	-----	ROD, float, 8 in.	1				
1kk†	-----	FLOAT, round, copper	1				

▲ Replacement Danger and Warning labels are available at no cost.

★ Elite models only.

⊗ Standard models only.

Part included in 6.5 Cubic Ft Pressure Pot Kit 17K046.

† Part included in Float Valve Kit 17K045.

* Part included in Pressure Pot Pop-Up Kit 25P252.

** Part included in D-Ring Bracket Kit 25P172.

! See **Common Spare Parts** page 58, for ball valve seal repair kit.

EQc and EQ200T / EQ400T Parts List

Ref.	Part	Description	Qty.	Ref.	Part	Description	Qty.
1#	-----	PRESSURE POT, abrasive media, 6.5 cu ft	1	34	17L332	STRAINER, in-line, 80 x 80 mesh, 3/4 npt	1
1a#	17L310	SEAL, o-ring	1	35	166469	NIPPLE, pipe hex	1
1d#	17D790	GASKET, handway	2	36■	EQ5183	CABLE, blast control switch, battery	1
1g#*	18A340PKG	PLUNGER, pot seal	1	37	128226	NUT, flange, 3/8-16, sst	4
1h#!	-----	BRACKET, d-ring; pop-up	2	40	EQ1934	COUPLER, sandblast, 1-1/2 npt(f)	1
1m#◆!	128504	BOLT, flange hd, serrated, 1/2, ss	4	49	17L633	TOOL, EQ, wrench, 2-7/8	2
1n#*	18A383PKG	HANDLE, tee, with stop	1	51	25D030	DOOR, enclosure, lg	1
1p#	129057	BOLT, square hd, 3/4 x 4-1/2, sst	1	52*	-----	GASKET, door, vertical	2
1q#	17K962	NUT, hex, 3/4-10, sst	1	53*	-----	GASKET, door, horizontal	2
1r	17R930	FITTING, nipple, reducing, 1 x 1/2, sst	1	54	111639	SCREW, cap, hex hd	4
1s	-----	MANIFOLD, dump	1	55	127918	NUT, flange, serrated, m5	4
1t	187873	GAUGE, pressure, fluid	1	56	17L623	LOCK, door, tooled (includes 57)	1
1u	EQ1500	FITTING, elbow, swivel, male, 3/8	1	57	-----	LATCH, cam, door lock	1
1v	17L622	VALVE, safety relief, 220 psi	1	58+	-----	DOOR, stay	1
1x	129903	VALVE, ball, 3/4 npt, brass, nickel	1	59+	128666	SCREW, cap, button hd, m6 x 16, sst	2
1y	EQ1012	FITTING, nipple, barb, hose, 3/4	1	60+	15U698	NUT, hex, flange, serrated	2
1bb#	-----	TRIM, edge, neoprene, black (6.25 ft)	1	62‡	17J958	TOOL, pressure verification	1
1cc	EQ1612	FITTING, nipple, hex, 1 NPT	1	64	EQ1846	COUPLER, 3/4 qd(f), 3/4 npt(m)	1
1dd	EQ1578	FITTING, elbow, street, 1 NPT	1	65★◆	-----	STRAINER, pressure pot	2
1ee•	17L046	VALVE, ball, 1 npt SST	1	67✿	555629	WASHER, #10 external tooth lock	1
1ff	113607	FITTING, 1 in. barb	1	68+❖	127908	NUT, flange, serrated, #10-32, ss	2
2	-----	ENCLOSURE, EcoQuip; see Enclosure Box Parts , page 48	1	+✿	127908	NUT, flange, serrated, #10-32, ss	3
7★	EQ1500	FITTING, elbow, swivel, male, 3/8	1	69✿▲	186620	LABEL, symbol, ground	1
8†	-----	BOX, tool, 20 in., black	1	70■	113864	UNION, swivel, 1-1/2 npt	1
9†	-----	INSERT, foam, tool box, EcoQuip	1	78★	24Z005	KIT, accessory, air inlet, 1-1/2 npt	1
10#	17H273	ADAPTER, tri-clamp, 1-1/4 npt, sst	1	107✿	194337	WIRE, grounding, door	1
11	680454	GASKET, sanitary fitting	7	108	EQ1840	HOSE, braided, clear, 3/8 ID	1
12	17L631	MANIFOLD, unequal-tee	1	110	17C124	GASKET, metal blast coupler	2
13	17L317	CLAMP, tri-clamp, 1.5, hex nut	1	150	17L642	VALVE, ball, 3/8 npt, sst	1
14	17L329	HOSE, inlet media	1				
15•	17L046	VALVE, ball, 1 npt SST	1				
16	17J329	COUPLER, cam-lock, sst, 1 npt(f)	1				
17✿■	112306	PLUG, pipe, 3/8 npt, sst	1				
18❖	18A604	FUSE, glass, 0.25 x 1.25, 400 MA	2				
19	17L309	GASKET, cam-lock, buna, 1.0	2				
20▲#	3A7468	LABEL, instructions	1				
21	502598	GASKET, sanitary (PTFE)	2				
24	17D787	PIN, safety item, hose, hair (6 pk)	2				
25	206994	FLUID, TSL 8 oz. bottle	1				
26	EQ1829	FITTING, ground boss, spud, 1-1/2	1				
28	17D786	KIT, replacement, whip check	2				
29	EQ1627	FITTING, nipple, barb, hose, 3/8	1				
32	12K344	FITTING, elbow, 3/4 npt, sst	1				
33	115813	FITTING, street elbow, 3/4 npt	1				

▲ Replacement Danger and Warning labels are available at no cost.
★ Elite models only.
❖ Non-ATEX models only.
✿ Standard models only.
✿ ATEX models only.
■ Custom models only.
Part included in 6.5 Cubic FT Pressure Pot Kit 17K046.
† Part included in Replacement Tool Box Kit 24Z156.
* Part included in Large Door Gasket Kit 17L625.
+ Part included in Door Stay Kit 17D686.
◆ Part included in Pot Strainer Kit 17K025.
‡ Part included in Pressure Verification Kit (purchased separately.)
• See **Common Spare Parts** page 58, for ball valve seal repair kit.
* Part included in Pressure Pot Pop-Up Kit 25P252.
! Part included in D-Ring Bracket Kit 25P172.

EQ200T Parts

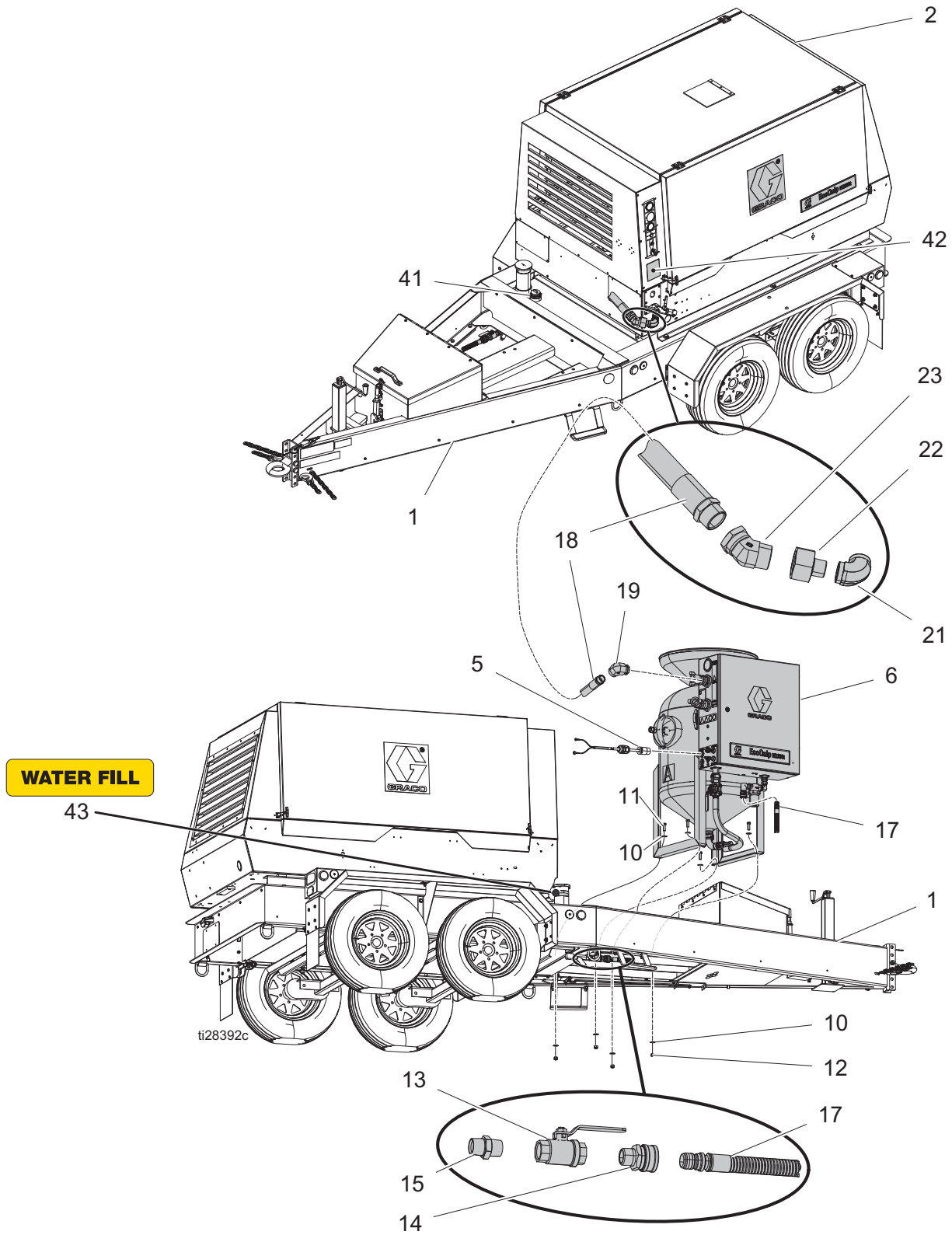

1. Apply thread sealant to all non-swivel pipe threads.

EQ200T Parts List

Ref.	Part	Description	Qty.	Ref.	Part	Description	Qty.
1*	-----	TRAILER, GL7, electric brakes	1	15*	190724	NIPPLE, sst	1
2	-----	COMPRESSOR, 210 cfm, skid mount	1	17*	EQ1848	HOSE, water, 3/4 in. ID	1
5*	17L039	CABLE, battery, deadman, trailer	1	18	17K877	HOSE, air, trailer system, GL7	1
6*	-----	MODLUE, EcoQuip, EQC, Elite, trailer	1	19	128934	FITTING, swivel, elbow, 1-1/2 npt, cs	1
10*	EQ1152	WASHER, flat, 1/2, sst	8	21	129011	FITTING, elbow, 90°, f x f, cs	1
11*	EQ1519	BOLT, hex hd, 1/2 x 1-1/2, sst	8	41*	128734	GAUGE, float	1
12*	EQ1475	NUT, lock, nylon insert, 1/2, sst	4	43*	17J290	LABEL, instructions	1
13*	EQ1003	VALVE, ball, 3/4 npt, sst	1	* Part included in Trailer Kit 279960.			
14*	EQ1846	COUPLER, 3/4 qd(f), 3/4 npt(m), brass	1				

NOTE: For information regarding KAESER compressors or compressor engines, refer to the KAESER compressor manual included with EcoQuip 2 Trailer Systems (or visit us.kaeser.com).

See **Trailer Kit Compressor Installation Guidelines (279960, 279970)**, page 62.

EQ400T Parts

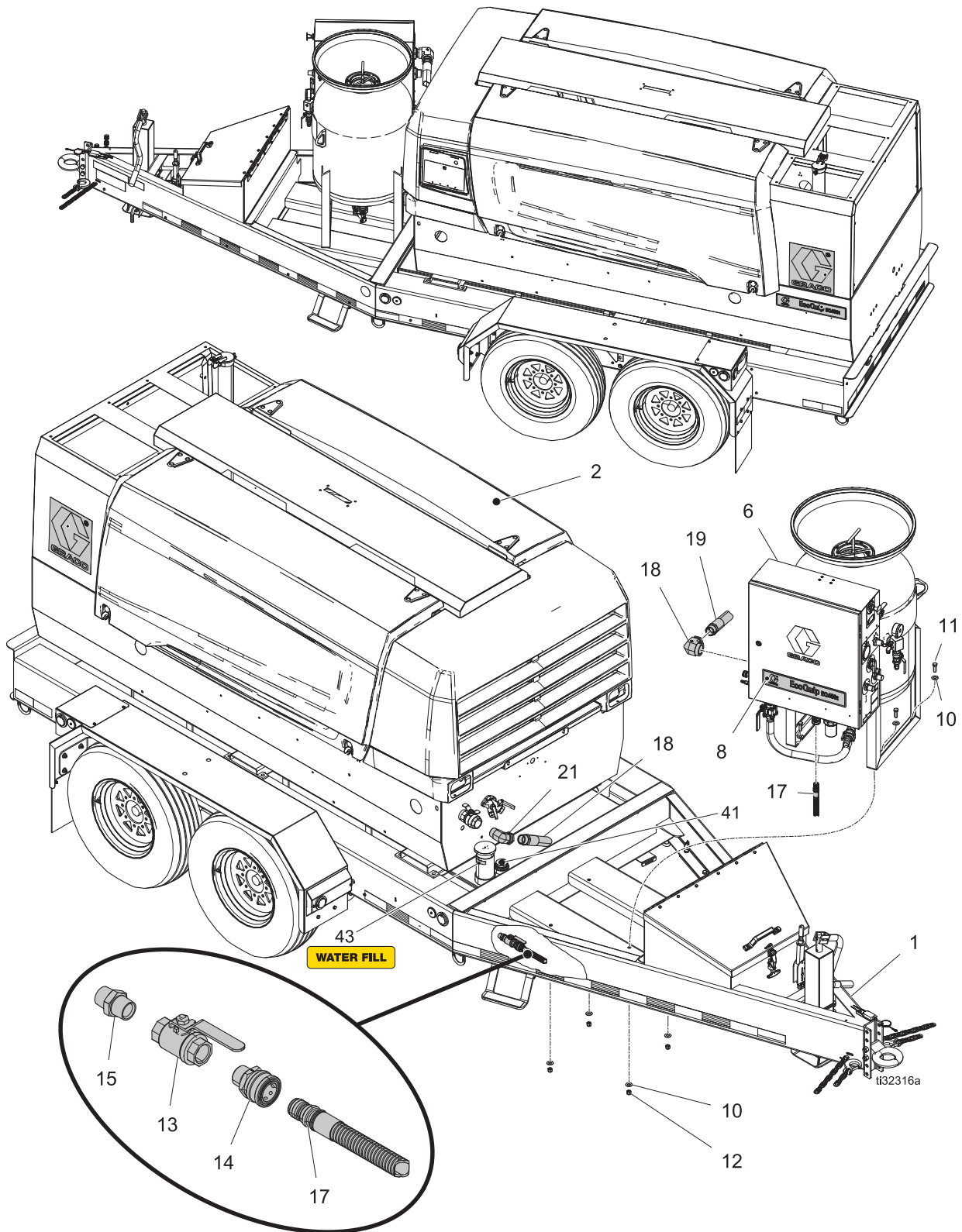

1. Apply thread sealant to all non-swivel pipe threads.

EQ400T Parts List

Ref.	Part	Description	Qty.	Ref.	Part	Description	Qty.
1*	-----	TRAILER, GL12, STD, electric brakes	1	14*	EQ1846	COUPLER, 3/4 EQ(f), 3/4 npt(m), brass	1
2	-----	COMPRESSOR, 400 cfm, skid mount, T4f	1	15*	190724	NIPPLE, sst	1
5*	17L039	CABLE, battery, deadman, trailer	1	17*	EQ1848	HOSE, inlet, water, 36 in.	1
6*	-----	MODULE, EcoQuip, EQc, Elite, trailer	1	18	17K878	HOSE, air, trailer system, GL10	1
10*	EQ1152	WASHER, flat, 1/2, sst	8	19	128934	FITTING, swivel, elbow, 1-1/2 npt, cs	1
11*	EQ1519	BOLT, hex hd, 1/2 x 1-1/2, sst	4	41*	128734	FITTING, elbow, 90°, m x f, cs	1
12*	EQ1475	NUT, lock, nylon insert, 1/2, sst	4	43*	17J290	LABEL, instruction	1
13*	EQ1003	VALVE, ball, 3/4 npt, sst	1	* Included in Trailer Kit 279970.			

NOTE: For information regarding the Atlas Copco compressor or compressor engine, refer to the Atlas Copco compressor manual included with EcoQuip 2 Trailer Systems (or visit www.atlascopco.com).

See **Trailer Kit Compressor Installation Guidelines (279960, 279970)**, page 62.

Enclosure Box Parts

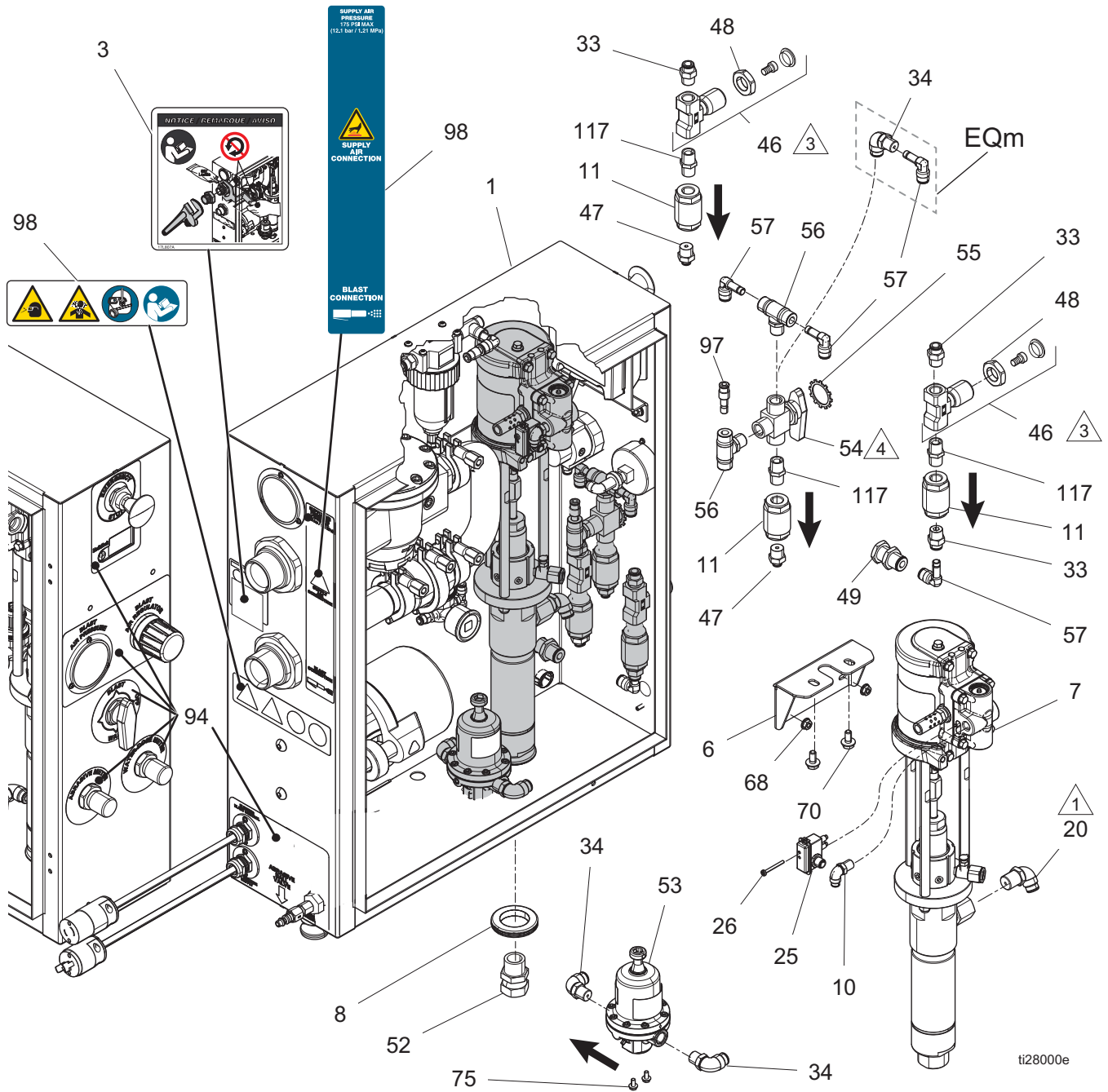

- Torque fitting with pump outlet fitting to 35–40 ft-lb (47.4–54.2 N•m).
- Apply thread sealant to needle valve knob screw when reassembling. Align knob with 'D' facing up when in closed position.
- Apply thread sealant to selector valve handle set screw when reassembling.

ti28000e

Enclosure Box Parts List

Ref.	Part	Description	Qty.	Ref.	Part	Description	Qty.
1	25D020	PANEL, enclosure, EQs Elite	1	49	EQ1115	BULKHEAD, connector, union, 3/8 in.	1
	25D022	PANEL, enclosure, EQs Standard	1				
3▲	17L807	LABEL, notice	1	52	112268	SWIVEL, union	1
6	-----	BRACKET, pump	1	53	17L324	REGULATOR, pressure, water, 185 psi (includes 75)	1
7	25A531	PUMP, water, sst, 3:1	1	54	17K055	VALVE, selector, 3-way, 3/8 npt, brass	1
8	128483	GROMMET, pump, EQ2	1	55	118160	WASHER, lock, external	1
10	121022	FITTING, elbow, male, 1/2 npt	1	56	EQ1832	FITTING, T, branch, swivel male	2
11	EQ1034	VALVE, check, 3/8 in., sst	3	57	EQ1122	FITTING, elbow, stem, 3/8 in.	4
20	EQ1798	FITTING, ptc, elbow, 1/2 mpt, 3/8 OD	1	68	127917	NUT, flange, serrated, 1/4-20, ss	4
25	24B659	SWITCH, reed assembly (includes 26)	1	70	111799	SCREW, cap, hex hd	2
26	-----	FASTENERS, screw, slot hex, #8-32 tap	1	75	128670	BOLT, flange hd, serrated, m5, sst	2
33	128638	FITTING, ptc, straight, 3/8	6	94▲	17J290	LABEL, instructions	1
34	EQ1500	FITTING, elbow, swivel, male, 3/8 in.	6	97	EQ1759	FITTING, stem, reducer	2
46	17K056	VALVE, needle, 3/8 npt, brass (includes 48)	2	98▲	17J291	LABEL, safety	1
47	128798	FITTING, ptc, 1/4 tube, 3/8 mpt	2	117	167702	NIPPLE, pipe	3
48	17H280	NUT, m20, needle valve	2				

▲ Replacement Danger and Warning labels are available at no cost.

Enclosure Box Parts List (continued)

Ref.	Part	Description	Qty.	Ref.	Part	Description	Qty.
4	-----	BRACKET, EcoQuip, DataTrak	1	69	17C001	GASKET, EcoQuip, DataTrak	1
5	17K057	ENCLOSURE, DataTrak, EcoQuip	1	72	128502	SCREW, pan, type F, #10-24, 3/8, sst	4
10	121022	FITTING, elbow, male 1/4 npt	5	76❖	-----	REGULATOR, air	1
22	17L319	GAUGE, flange mount, 2.5 in., 200 psi	2	77	128672	NUT, serrated flange, #6-32, sst	4
23	128725	FITTING, ptc, 1/4 tube, 1/4 npt	1	79‡	127929	SCREW, sems, #6-32, 3/8 in., sst	10
24	EQ1113	FITTING, elbow, swivel, female	1	80‡	19Y239	CABLE, male plug, EQs	1
27	25E922	CABLE, fuse holder, EQs	1	81‡	25P357	CABLE, female plug, EQs	1
29*	106148	FILTER, air, 3/8 npt	1	84	121021	MUFFLER, 1/4 npt	2
30	128273	FITTING, barb x npt, brass	1	95	128888	FITTING, ptc, 1/4 tube, m5	1
31	EQ1840	HOSE, braided, clear, 3/8 ID	2	96	128500	PLUG, hole, snap-in, black, 22 mm	2
32	128634	FITTING, ptc, tee, run, 3/8 in.	1	97	EQ1759	FITTING, stem, reducer	2
33	128638	FITTING, ptc, straight, 3/8 in.	4	103	128892	PLUG, hole, black	2
34	EQ1500	FITTING, elbow, swivel, male, 3/8 in.	5	105▲	16P265	LABEL, safety, warning, explosion	1
35	17G567	BRACKET, regulator, EQ2	1	106	100985	WASHER, lock ext	1
36	17L322	REGULATOR, air, adj, 100 psi	1	107	194337	WIRE, grounding, door	1
37	15K040	NUT, regulator	1	108▲	186620	LABEL, symbol, ground	2
38	17L323	GAUGE, pressure, 1-1/2 in., 160 psi.	1	109	237686	WIRE, ground assembly with clamp	1
39	123390	FITTING, 1/4 npt, brass	2	110	555629	WASHER, #10 external tooth lock	1
40	EQ1814	FILTER, in-line, 1/4 npt(m)	1	114	128863	FITTING, ptc, elbow, 1/4 OD, 1/8 npt	1
41	EQ1421	COUPLER, air, 1/4 qd(m), 1/4 npt(f), brass	1	115	128864	FITTING, ptc, tee, branch, 1/4 OD, 1/8 npt	1
42	EQ1813	COUPLER, air, 1/4 qd(f), 1/4 npt(m), brass	1	116	101970	PLUG, pipe, handles	1
43	128479	MANIFOLD, 4-port, 1/4 npt	1	118†	-----	REGULATOR, air, 1.75 in. (44.5 mm) OD only	1
44	128636	FITTING, ptc, 3/8 tube, 1/4 npt	1	119†	-----	NUT, regulator	1
45	128637	FITTING, ptc, straight, 1/4	7	122‡	-----	PLATE, adapter, wire	2
50	16N177	FITTING, bulkhead, brass, 3/8	1				
51	17K053	VALVE, solenoid, elec/pneu, assembly	1				
	17K054	VALVE, solenoid, pneumatic, ATEX	1				
57	EQ1122	FITTING, elbow, stem, 3/8 in.	3				
58	EQ5108	VALVE, 3-way, e-stop, 3/8 in., (f)pt 3-port	1				
59	EQ1438	VENT, breather, 3/8 npt	1				
63	127908	NUT, flange, serrated, #10-32, ss	2				
67❖	-----	NUT, regulator	1				
68	127917	NUT, flange, serrated, 1/4-20, ss	2				

▲ Replacement Danger and Warning labels are available at no cost.

* See **Common Spare Parts**, page 58, for replacement filter element.



† Part included in Air Regulator Kit 25P174 (purchase separately).

‡ Part included in Cable Plug Upgrade Kit 19Y238 (purchase separately).

❖ Part included in Pressure Regulator Kit 19Y249 (sold separately)

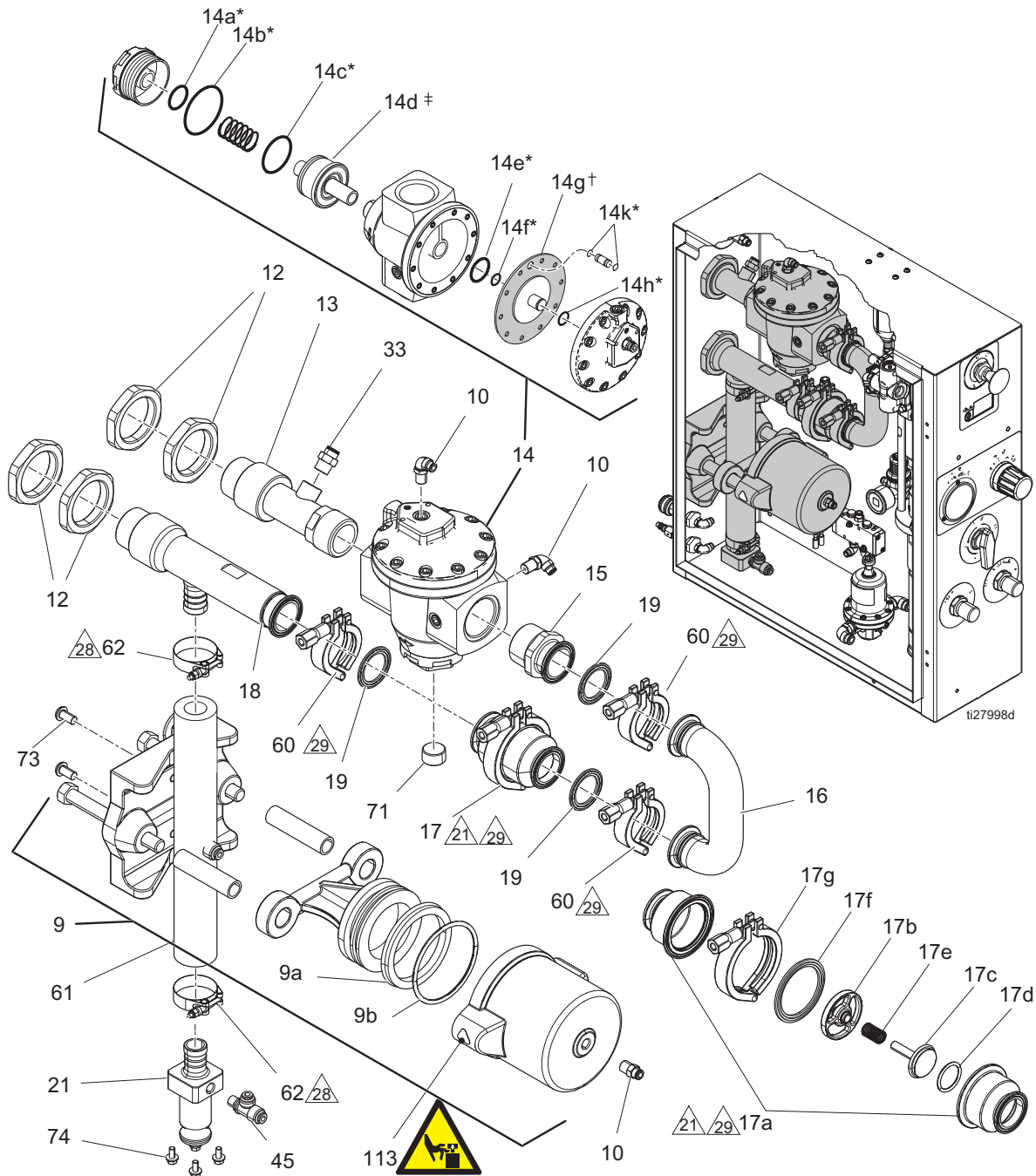
Enclosure Parts



-  Assemble valve (17) with plunger facing the bent manifold (16).
-  Apply anti-seize to threads on clamp (62). Align the nuts pointing towards the front of the enclosure. Torque nuts to 85 +/- 5 in-lb (9.6 +/- 0.5 N*m).

-  Apply anti-seize to threads on clamp (60). Align the nuts pointing towards the front of the enclosure. Torque nuts to 15 +/- 2 ft-lb (20.3 +/- 2.7 N*m).

* Included in Kit 17F536.

† Included in Kit 17C131.

‡ Included in Kit 17F535.

Enclosure Parts List

Ref.	Part	Description	Qty.	Ref.	Part	Description	Qty.
9	17K052	VALVE, pinch	1	18	17F436	MANIFOLD, blast circuit, 1.5, bottom	1
9a	-----	SEAL, wiper	1				
9b	-----	SEAL, o-ring	1	19	680454	GASKET, sanitary fitting	3
10*	121022	FITTING, elbow, male, 1/4 npt	3	21	-----	MANIFOLD, slurry, barb/cam-lock	1
12	17G574	NUT, bulkhead, 2-1/4, sst	4	33*	128638	FITTING, ptc, straight, 3/8	1
13*	17F438	MANIFOLD, blast circuit, 1.5, top	1	45	17E553	FITTING, ptc, run tee 1/4 npt, 1/4	1
14*	25M473	REGULATOR, main air, non-relieving	1	60	17L317	CLAMP, tri-clamp, 1.5, hex wing nut	3
15*	17G576	ADAPTER, tri-clamp, 1-1/2 npt, sst	1	61	17K051	HOSE, pinch	1
16	17F437	MANIFOLD, blast circuit, 1.5, bend	1	62	128642	CLAMP, hose, t-bolt, 1.75-2.00, sst	2
17	-----	VALVE, check, sanitary, 1-1/2 in.	1	71*	111384	PLUG, pipe	1
17a	17K049	VALVE, check, housing	1	73	128787	BOLT, button hd, 3/8-16 x 3/4, ss	2
17b	17L376	VALVE, check, guide	1	74	128504	BOLT, flange hd, serrated, 1/4, ss	4
17c	17L377	VALVE, check, piston	1	113▲	15F744	LABEL, warning, ISO pinch hazard	1
17d	17L378	VALVE, check, o-ring, 5-pack	1				
17e	17L375	VALVE, check, spring	1				
17f	17L313	GASKET, sanitary, 2-1/2 in.	1				
17g	17L318	TRI-CLAMP, 2-1/2 in.	1				

▲ Replacement Danger and Warning labels are available at no cost.

* Part included in Kit 17L314.

For Use with Standard Electric Plugs

Electric, 50 ft
28A024 (1.25 in.), 28A074 (1.0 in.)

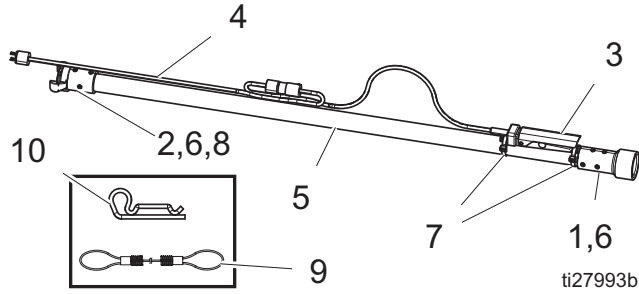

ti27993b

Electric Extension, 50 ft
28A026 (1.25 in.), 28A076 (1.0 in.)

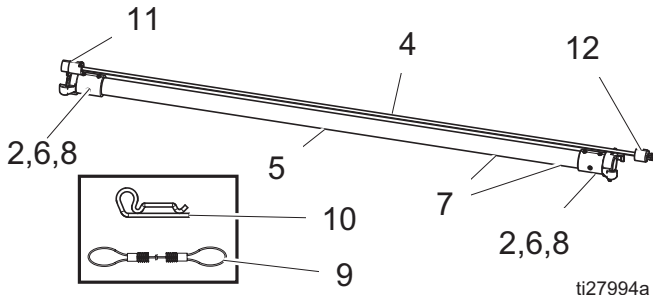

ti27994a

Ref.	Part	Description	Qty.
1	17L274	HOLDER, 1.25 in.	1
	17L276	HOLDER, 1.0 in.	1
2	17L273	COUPLER, 1.25 in.	1
	17L275	COUPLER, 1.0 in.	1
3	17D791	HANDLE, switch, electric	1
4	17F506	CABLE, blast control	1
5	17L472	HOSE, blast, 1.25 in. ID	1
	17L473	HOSE, extension, 1.25 in. ID	1
	17L474	HOSE, blast, 1.0 in. ID	1
	17L475	HOSE, extension, 1.0 in ID	1
6	17L476	KIT, screws, flat hd, sst, 8 pk	1
7	17H240	KIT, cable ties, 6 pk	1
8	17C124	GASKET, brass, blast coupler	1
9	17D786	KIT, replacement, whip check	1
10	17D787	KIT, replacement, hairpin, hose	1
11	EQ1863	CONNECTOR, twist-lock, f	1
12	EQ1864	CONNECTOR, twist-lock, m	1

Vapor Abrasive Blast Systems and Accessories

50 ft (15 m) Blast Hoses with Control Hose/Cable

Part	ID	Blast Control	Electric Plug Type	Coupler 1	Coupler 2	ATEX Approved
26A077	1.0 in.	Pneumatic		2-prong coupler, brass	2-prong coupler, brass	Yes
26A076	1.0 in.	Electric	Mini			No
28A076	1.0 in.	Electric	Standard			No
26A075	1.0 in.	Pneumatic		Nozzle holder, brass		Yes
26A074	1.0 in.	Electric	Mini			No
28A074	1.0 in.	Electric	Standard			No
26A026	1.25 in.	Electric	Mini	2-prong coupler, brass		No
28A026	1.25 in.	Electric	Standard			No
26A027	1.25 in.	Pneumatic				Yes
26A025	1.25 in.	Pneumatic		Nozzle holder, brass		Yes
26A024	1.25 in.	Electric	Mini			No
28A024	1.25 in.	Electric	Standard			No

50 ft (15 m) Blast Hoses without Control Hose/Cable

Part	ID	Blast Control	Coupler 1	Coupler 2	ATEX Approved
17L474	1.0 in.	None	Nozzle holder, brass	2-Prong coupler, brass	Yes
17L475	1.0 in.		2-Prong coupler, brass		
17L472	1.25 in.		Nozzle holder, brass		
17L473	1.25 in.		2-Prong coupler, brass		

Control Hoses/Cable with Blast Hose

Part	Description
24X746	Blast control hose, pneumatic control line, 55 ft, ATEX approved
24X744	Blast control hose, pneumatic control line, 55 ft, extension, ATEX approved
17L471	Blast control cable, electric, 55 ft, mini plug
17F506	Blast control cable, electric, 55 ft, standard plug

Nozzles

Part	Description	Length	Thread Size
17J859	Nozzle, #7 standard	7.8 in.	50 mm Contractor Thread (2 in. 4-1/2 UNC-2A)
17J860	Nozzle, #8 standard	8.8 in.	
17J861	Nozzle, #10 standard	9.0 in.	
17J862	Nozzle, #12 standard	9.0 in.	
17K898	Nozzle, #6 high performance*	12.0 in.	
17J855	Nozzle, #7 high performance*	12.0 in.	
17J856	Nozzle, #8 high performance*	12.0 in.	
17J858	Nozzle, #10 high performance*	12.0 in.	

* High performance nozzles require 100 psi (7 bar, 0.7 MPa) or more air pressure at nozzle.

EQ200T (M58 Kaeser Compressor)

Part	Description
129219	KIT, fluid, separator
129221	KIT, air inlet filter
129223	KIT, fluid filter
129229	KIT, engine, fluid filter
129288	PUMP, fuel
129290	CAP, fuel tank
129289	SWITCH, temp

EQ400T (Atlas Copco Compressor)

Part	Description
129708	KIT, service, 500 hr, Atlas Copco

Other Accessories

Part	Description
17L119	KIT, nozzle gasket (pack of 5)
EQ5166	KIT, nozzle extension, 24 in. (0.6 m)
26A029	KIT, nozzle extension, 24 in. (0.6 m), with handles
17J958	KIT, nozzle pressure verification tool
17G833	KIT, hose rack, SST, skid units
256263	KIT, hose rack, painted, silver, skid units
17K025	KIT, pot strainer
17K026	KIT, bag shelf, SST, skid units
17K045	KIT, water tank inlet with float valve
26A007	KIT, step, skid units
24Z005	KIT, inlet ball valve/stainer kit, EQ2 units
25A253	KIT, bull hose, 25 ft
25A254	KIT, bull hose, 50 ft

Part	Description
24Z156	KIT, tool box with insert
17L624	KIT, gaskets, small door
17L625	KIT, gaskets, large door
17K046	KIT, pressure pot, 6.5 cubic ft
17D686	KIT, door stay
EQ1907	LID, tank, 5 in., vented, 2-way
19Y238	KIT, cable plug upgrade

Common Spare Parts

Part	Description
17D786	Hose restraint / Whip check
17D787	Blast hose coupler pin kit (6 pack)
17L119	Gasket, blast nozzle (5 pack)
17L313	Blast circuit gasket kit (10 pack)
26A093	Water tank filter w/adapter (5 pack)
206994	Throat seal liquid (TSL)
17B186	Pump repair, lower
17C131	Main air regulator diaphragm repair kit (skid or trailer units)
17F535	Air regulator piston repair kit (skid or trailer units)
17F536	Air regulator o-ring repair kit (skid or trailer units)
17L310	O-ring, pop-up
17D790	Gasket, handway
17L333	Pump, inlet filter replacement
EQ1818	Air filter, replacement, inside enclosure
17K051	Pinch hose replacement kit
17L046	Abrasive ball valve replacement
18B807PKG	1 NPT SST ball valve seal repair kit

Tubing Schematic

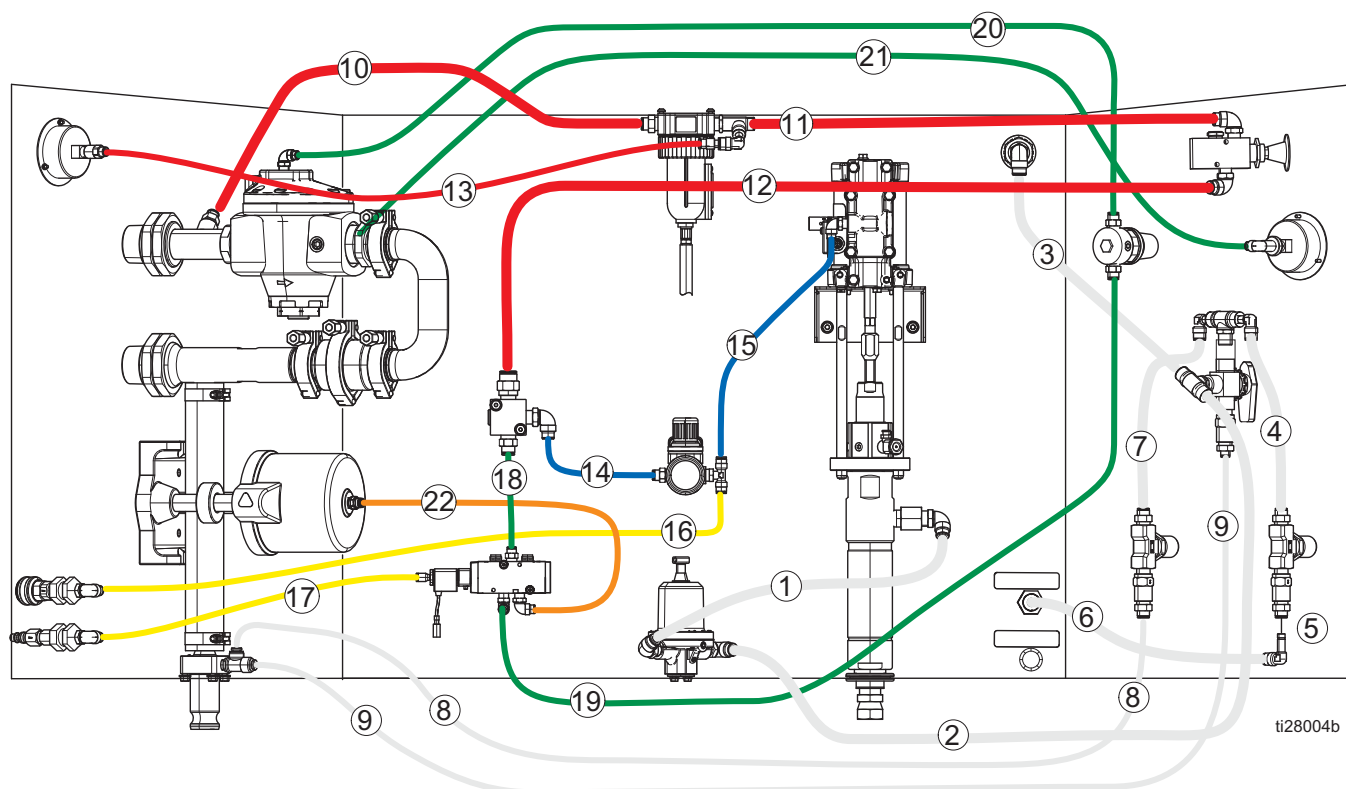

Ref.	Part	Color, Tube Size	Cut Length inches (mm)	
			EQs	EQs Elite
1	EQ1273	Natural, 3/8 in. OD	12.25 (311)	12.25 (311)
2	EQ1273	Natural, 3/8 in. OD	17 (432)	17 (432)
3	EQ1273	Natural, 3/8 in. OD	19 (483)	19 (483)
4	EQ1273	Natural, 3/8 in. OD	5.25 (133)	5.25 (133)
5	EQ1273	Natural, 3/8 in. OD	2.25 (57)	2.25 (57)
6	EQ1273	Natural, 3/8 in. OD	6 (152)	6 (152)
7	EQ1273	Natural, 3/8 in. OD	5.25 (133)	5.25 (133)
8	EQ1881	Natural, 1/4 in. OD	24 (610)	24 (610)
9	EQ1881	Natural, 1/4 in. OD	27 (686)	27 (686)
10	EQ1297	Red, 3/8 in. OD	13.5 (343)	13.5 (343)
11	EQ1297	Red, 3/8 in. OD	7.25 (184)	7.25 (184)
12	EQ1297	Red, 3/8 in. OD	27 (686)	27 (686)
13	EQ1882	Red, 1/4 in. OD	12.5 (318)	12.5 (318)
14	EQ1883	Blue, 1/4 in. OD	7.5 (191)	7.5 (191)
15	EQ1883	Blue, 1/4 in. OD	21.5 (572)	21.5 (572)
16	EQ1885	Yellow, 1/4 in. OD	22.5 (572)	22.5 (572)
17	EQ1885	Yellow, 1/4 in. OD	9.25 (235)	9.25 (235)
18	EQ1884	Green, 1/4 in. OD	8.25 (210)	8.25 (210)
19	EQ1884	Green, 1/4 in. OD	23 (584)	23 (584)
20	EQ1884	Green, 1/4 in. OD	23 (584)	23 (584)
21	EQ1884	Green, 1/4 in. OD	18 (457)	18 (457)
22	EQ1296	Orange, 1/4 in. OD	13 (330)	13 (330)

Dimensions

EQs and EQs Elite Models

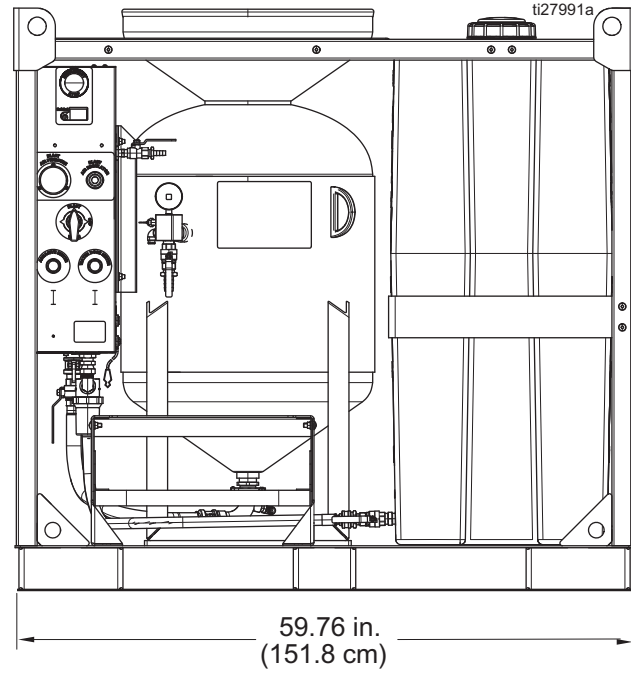
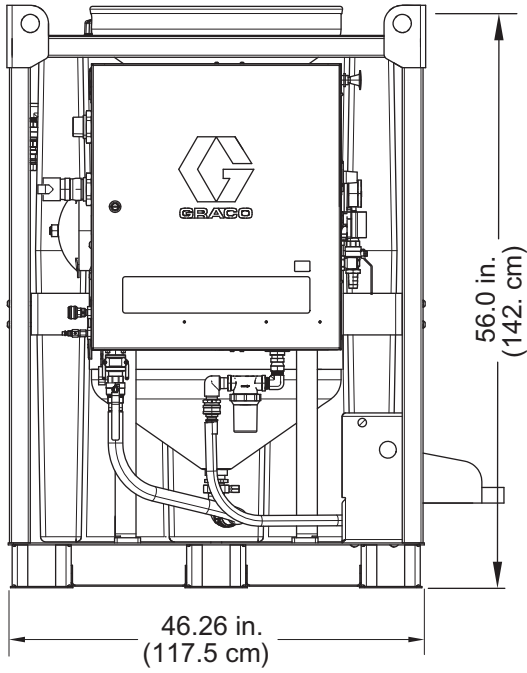

EQc Models

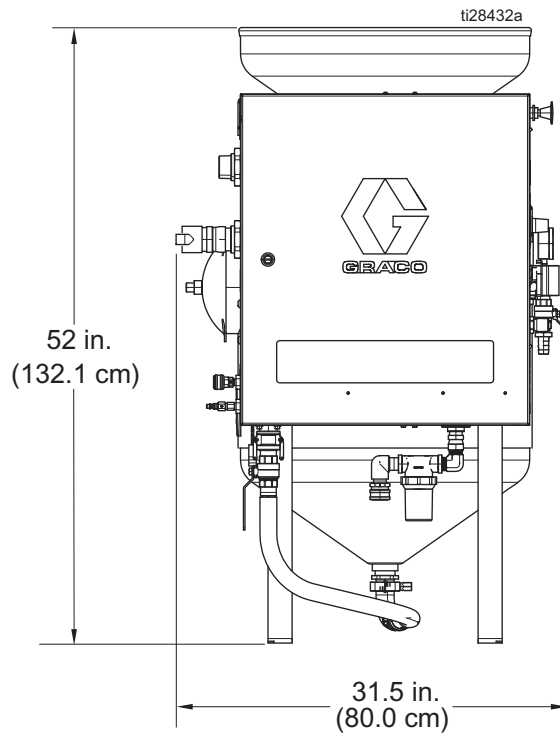
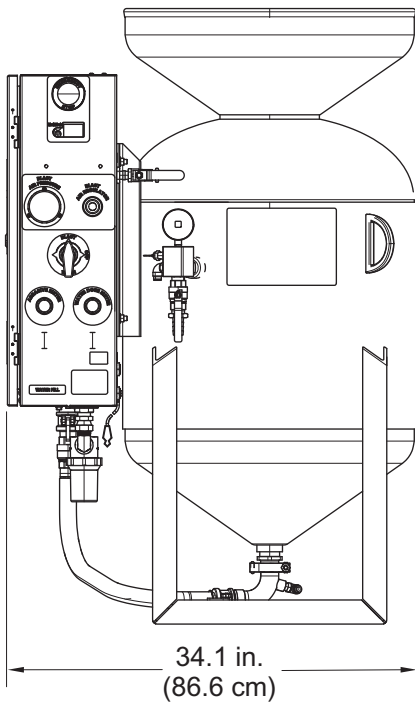

EQ Trailer Models

EQ200T

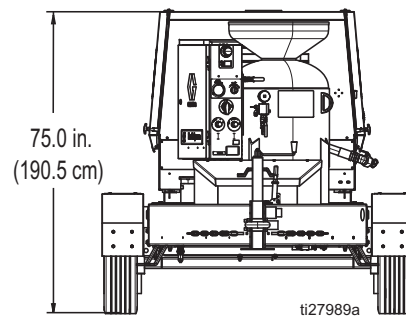
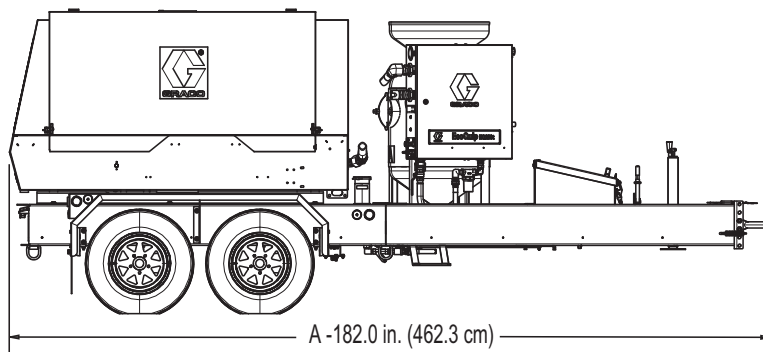
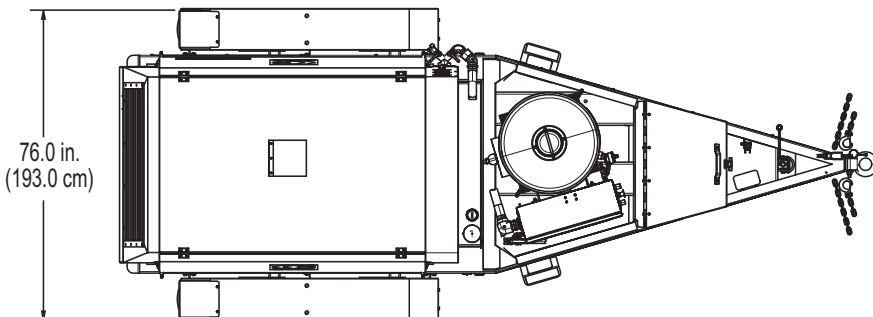

EQ400T

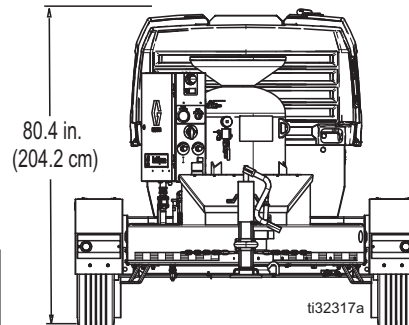
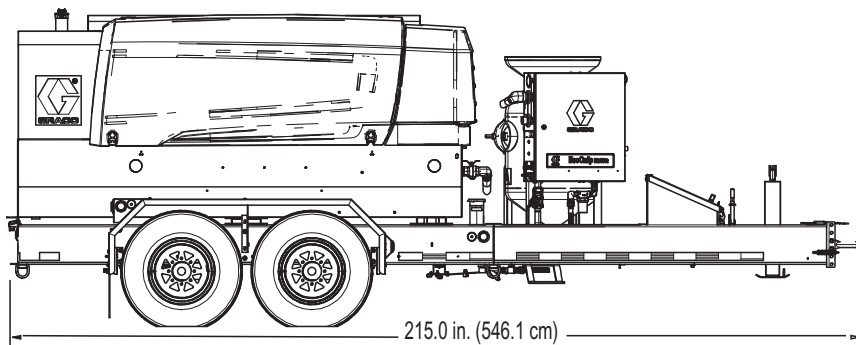
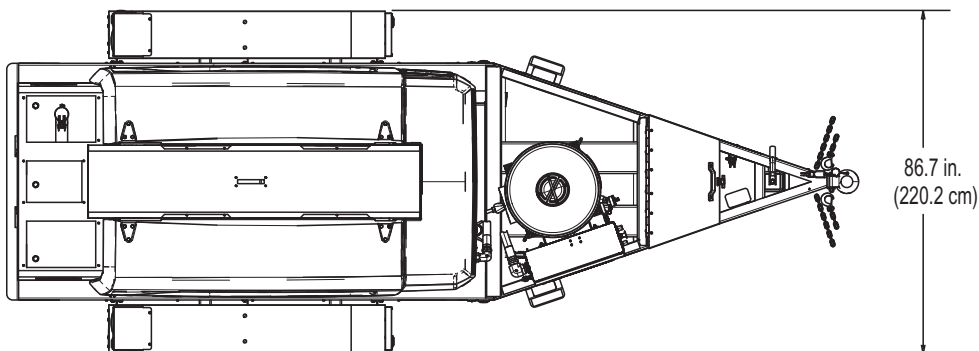

Trailer Kit Compressor Installation Guidelines (279960, 279970)

1. Tongue weight should be 10% of the overall trailer weight. Adjust compressor location forward/back as needed.
2. The compressor must be mounted down the lengthwise center-line of the trailer.
3. The exhaust point must be pointed away from the EcoQuip unit.
4. Mount the compressor to the trailer using the guidelines given in the compressor manual. If possible, use the compressor manufacturer's recommended mounting skid to mount to the compressor.

NOTE: Graco is not responsible for damage caused by or related to the mounting of the compressor.

Trailer Mounting Area Dimensions

GL7 Trailer (279960)

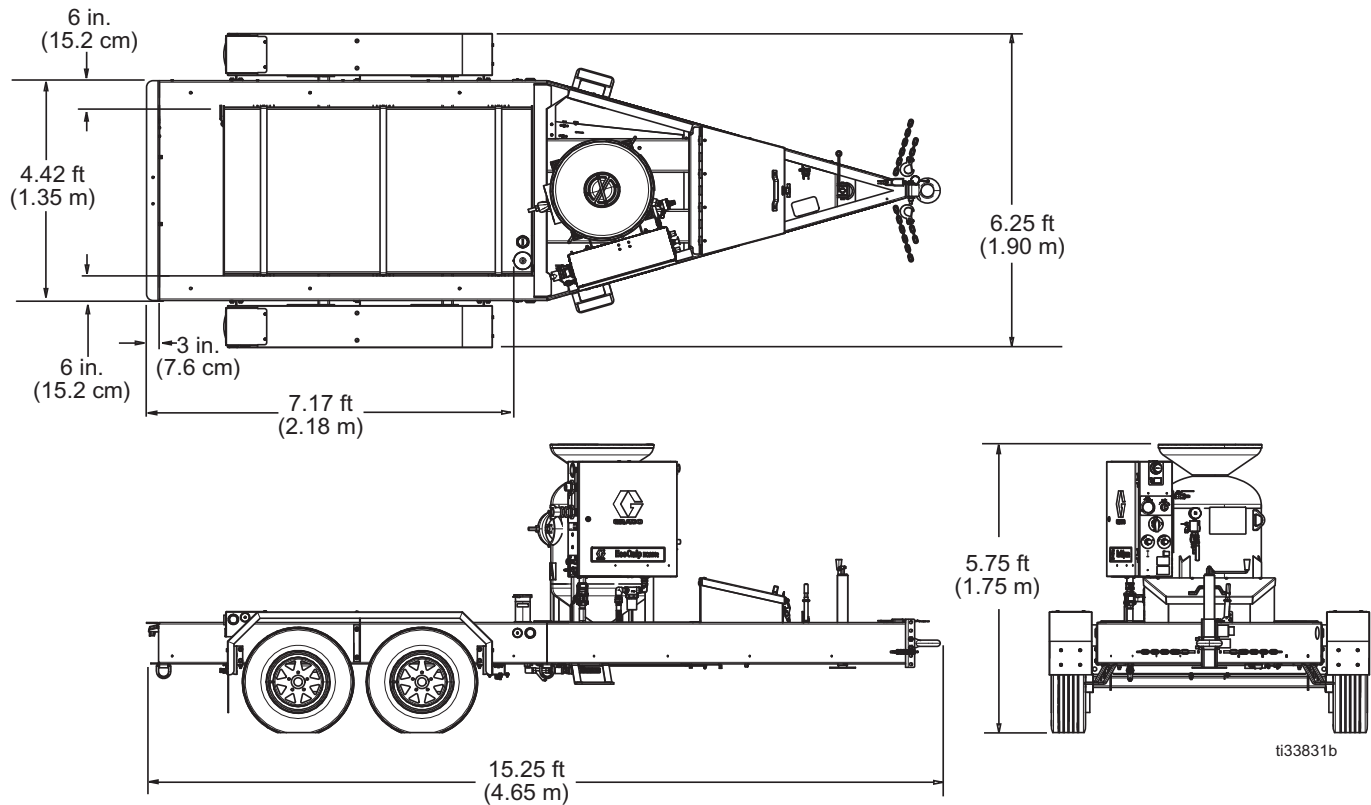

Maximum allowable compressor weight: 4265 lb (1935 kg)
 Recommended compressor size: 200 cfm

GL12 Trailer (279970)

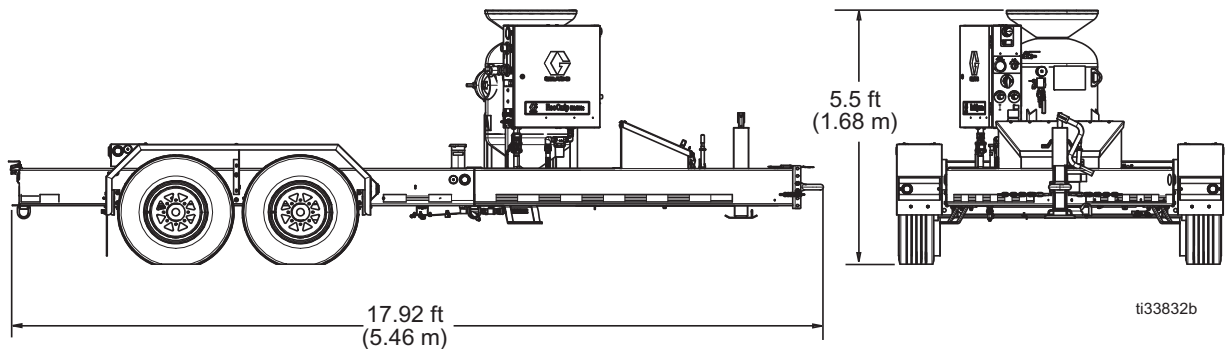
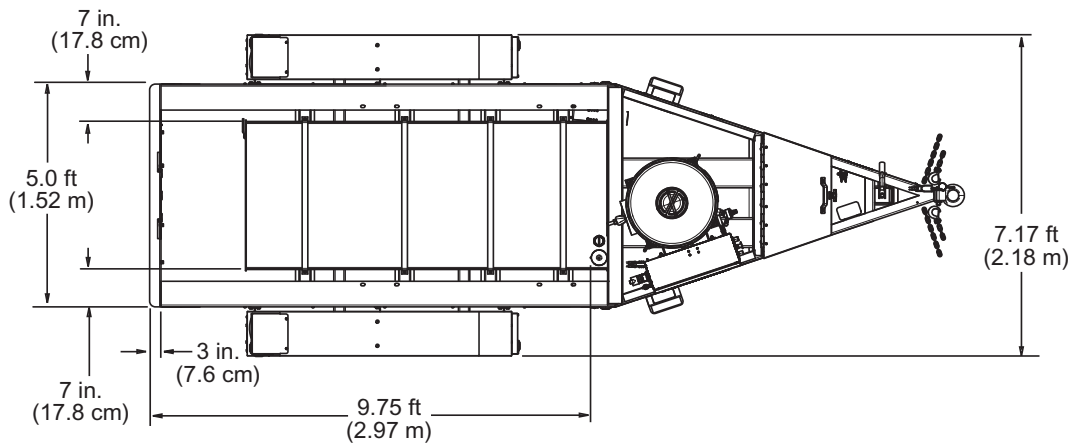

Maximum allowable compressor weight: 7414 lb (3363 kg)
Recommended compressor size: 400 cfm

Technical Specifications

EQs Elite

EcoQuip 2 EQs and EQs Elite		
	US	Metric
Maximum Fluid Working Pressure	175 psi	10.3 bar, 1.03 MPa
Operating Temperature	35°–110° F	1.6°–43.3° C
Recommended Compressor Size+	185–900 CFM	5.24–25.5 m ³ /min
Blast Hose Size (supplied)	1.25 in. ID	31.75 mm ID
Abrasive Capacity*	880 lb	400 kg
Dry Weight	1070 lb	485 kg
Wet Weight*	3120 lb	1415 kg
Pressure Pot Volume	6.5 cubic feet	184 liters
Water Tank Volume	115 gallon	435 liters
Air Inlet Connection†	1-1/2 npt	
Water Inlet Connection	3/4 in. garden hose connection	19 mm garden hose connection
*Abrasive capacity and wet weight was found using 80 grit garnet. Using coarser media or less dense media will decrease weight.		
† 2 in. ground boss adapter included in tool box (see Parts section of the EcoQuip 2 manual for more detail).		
Air Supply Hose Minimum ID		
185–600 CFM compressor and less than 100 ft hose length	1.5 in. ID	38 mm ID
Over 600 CFM compressor or greater than 100 ft hose length	2 in. ID	51 mm ID
Sound Data**		
Sound Pressure Level	133 dB(A)	133 dB(A)
Sound Power Level	139 dB(A)	139 dB(A)
Instantaneous Sound Pressure Level	131 dB(C)	131 dB(C)
**All readings were taken at the maximum system blast pressure 150 psi (10.3 bar, 1.03 MPa) from the operator position. The abrasive used was garnet and the substrate was steel. Tested in accordance with ISO 9614-2.		
+ See the Nozzle Selection Guide for information on how to properly select the blast nozzle based on compressor pressure and flow output specifications.		
Notes		
All trademarks or registered trademarks are the property of their respective owners.		

EQc and EQc Elite

EcoQuip 2 EQc and EQc Elite		
	US	Metric
Maximum fluid working pressure	175 psi	10.3 bar, 1.03 MPa
Operating Temperature	35°–110° F	1.6°–43.3° C
Recommended Compressor Size+	185–900 CFM	5.24–25.5 m ³ /min
Blast Hose Size	1.25 in. ID	31.75 mm ID
Abrasive Capacity*	880 lb	400 kg
Dry Weight	450 lb	204 kg
Wet Weight*	1500 lb	680 kg
Pressure Pot Volume	6.5 cubic feet	184 liters
Water Tank Volume	115 gallon	435 liters
Air Inlet Connection†	1-1/2 npt	
Pump Inlet Fitting	Dixon 6EM6-B quick disconnect interchange included (3/4 in. NPT also on pump)	
Minimum Inlet Hose ID	5 ft	4.5 m
Maximum Recommended Rise from Water Tank Outlet to Pump Inlet	16 in.	41 cm
*Abrasive capacity and wet weight was found using 80 grit garnet. Using coarser media or less dense media will decrease weight.		
† 2 in. ground boss adapter included in tool box (see Parts section of the EcoQuip 2 manual for more detail).		
Air Supply Hose Minimum ID		
185–600 CFM compressor and less than 100 ft hose length	1.5 in. ID	38 mm ID
Over 600 CFM compressor or greater than 100 ft hose length	2 in. ID	51 mm ID
Sound Data**		
Sound Pressure Level	133 dB(A)	133 dB(A)
Sound Power Level	139 dB(A)	139 dB(A)
Instantaneous Sound Pressure Level	131 dB(C)	131 dB(C)
**All readings were taken at the maximum system blast pressure 175 psi (12.1 bar, 1.21 MPa) from the operator position. The abrasive used was garnet and the substrate was steel. Tested in accordance with ISO 9614-2.		
+ See the Nozzle Selection Guide for information on how to properly select the blast nozzle based on compressor pressure and flow output specifications.		
Notes		
All trademarks or registered trademarks are the property of their respective owners.		

EQ200T Elite

EcoQuip 2 EQ200T Elite		
	US	Metric
Maximum Working Pressure	100 psi	6.89 bar, 0.69 MPa
Operating Temperature	35°–110° F	1.6°–43.3° C
Blast Hose Size	1.25 in. ID	31.75 mm ID
Abrasive Capacity*	880 lb	400 kg
Pressure Pot Volume	6.5 cubic feet	184 liters
Water Tank Volume	100 gallon	378 liters
GVWR	6600 lb	2993 kg
Air Consumption	210 CFM	5.9 m ³ /min
EPA Emission Standard Rating	Tier 4f	
*Abrasive capacity and wet weight was found using 80 grit garnet. Using coarser media or less dense media will decrease weight.		
Trailer Connections		
Hitch Size	3 in. Lunette Ring (Pintel Eye)	
Electrical Connector	7-way Flat Pin	
Sound Data**		
Sound Pressure Level	133 dB(A)	133 dB(A)
Sound Power Level	139 dB(A)	139 dB(A)
Instantaneous Sound Pressure Level	131 dB(C)	131 dB(C)
**All readings were taken at the maximum system blast pressure 150 psi (12.1 bar, 1.21 MPa) from the operator position. The abrasive used was garnet and the substrate was steel. Tested in accordance with ISO 9614-2.		
Notes		
All trademarks or registered trademarks are the property of their respective owners.		

EQ400T Elite

EcoQuip 2 EQ400T Elite		
	US	Metric
Maximum Working Pressure	150 psi	10.3 bar, 1.03 MPa
Operating Temperature	35°–110° F	1.6°–43.3° C
Blast Hose Size	1.25 in. ID	31.75 mm ID
Abrasive Capacity*	880 lb	400 kg
Pressure Pot Volume	6.5 cubic feet	184 liters
Water Tank Volume	130 gallon	492 liters
GVWR	9,999 lb	4,535 kg
Air Consumption	397 CFM	11.2 m ³ /min
EPA Emission Standard Rating	Tier 4f	
*Abrasive capacity and wet weight was found using 80 grit garnet. Using coarser media or less dense media will decrease weight.		
Trailer Connections		
Hitch Size	3 in. Lunette Ring (Pintel Eye)	
Electrical Connector	7-way Flat Pin	
Sound Data**		
Sound Pressure Level	133 dB(A)	133 dB(A)
Sound Power Level	139 dB(A)	139 dB(A)
Instantaneous Sound Pressure Level	131 dB(C)	131 dB(C)
**All readings were taken at the maximum system blast pressure 150 psi (12.1 bar, 1.21 MPa) from the operator position. The abrasive used was garnet and the substrate was steel. Tested in accordance with ISO 9614-2.		
Notes		
All trademarks or registered trademarks are the property of their respective owners.		

California Proposition 65

 **WARNING:** This product can expose you to chemicals known to the State of California to cause cancer and birth defects or other reproductive harm. For more information, go to www.P65warnings.ca.gov.

 **WARNING:** Breathing diesel engine exhaust exposes you to chemicals known to the State of California to cause cancer and birth defects or other reproductive harm.

- Always start and operate the engine in a well-ventilated area.
- If in an enclosed area, vent the exhaust to the outside.
- Do not modify or tamper with the exhaust system.
- Do not idle the engine except as necessary.

For more information, go to www.P65warnings.ca.gov/diesel.

Graco Standard Warranty

Graco warrants all equipment referenced in this document which is manufactured by Graco and bearing its name to be free from defects in material and workmanship on the date of sale to the original purchaser for use. With the exception of any special, extended, or limited warranty published by Graco, Graco will, for a period of twelve months from the date of sale, repair or replace any part of the equipment determined by Graco to be defective. This warranty applies only when the equipment is installed, operated and maintained in accordance with Graco's written recommendations.

This warranty does not cover, and Graco shall not be liable for general wear and tear, or any malfunction, damage or wear caused by faulty installation, misapplication, abrasion, corrosion, inadequate or improper maintenance, negligence, accident, tampering, or substitution of non-Graco component parts. Nor shall Graco be liable for malfunction, damage or wear caused by the incompatibility of Graco equipment with structures, accessories, equipment or materials not supplied by Graco, or the improper design, manufacture, installation, operation or maintenance of structures, accessories, equipment or materials not supplied by Graco.

This warranty is conditioned upon the prepaid return of the equipment claimed to be defective to an authorized Graco distributor for verification of the claimed defect. If the claimed defect is verified, Graco will repair or replace free of charge any defective parts. The equipment will be returned to the original purchaser transportation prepaid. If inspection of the equipment does not disclose any defect in material or workmanship, repairs will be made at a reasonable charge, which charges may include the costs of parts, labor, and transportation.

THIS WARRANTY IS EXCLUSIVE, AND IS IN LIEU OF ANY OTHER WARRANTIES, EXPRESS OR IMPLIED, INCLUDING BUT NOT LIMITED TO WARRANTY OF MERCHANTABILITY OR WARRANTY OF FITNESS FOR A PARTICULAR PURPOSE.

Graco's sole obligation and buyer's sole remedy for any breach of warranty shall be as set forth above. The buyer agrees that no other remedy (including, but not limited to, incidental or consequential damages for lost profits, lost sales, injury to person or property, or any other incidental or consequential loss) shall be available. Any action for breach of warranty must be brought within two (2) years of the date of sale.

GRACO MAKES NO WARRANTY, AND DISCLAIMS ALL IMPLIED WARRANTIES OF MERCHANTABILITY AND FITNESS FOR A PARTICULAR PURPOSE, IN CONNECTION WITH ACCESSORIES, EQUIPMENT, MATERIALS OR COMPONENTS SOLD BUT NOT MANUFACTURED BY GRACO. These items sold, but not manufactured by Graco (such as electric motors, switches, hose, etc.), are subject to the warranty, if any, of their manufacturer. Graco will provide purchaser with reasonable assistance in making any claim for breach of these warranties.

In no event will Graco be liable for indirect, incidental, special or consequential damages resulting from Graco supplying equipment hereunder, or the furnishing, performance, or use of any products or other goods sold hereto, whether due to a breach of contract, breach of warranty, the negligence of Graco, or otherwise.

FOR GRACO CANADA CUSTOMERS

The Parties acknowledge that they have required that the present document, as well as all documents, notices and legal proceedings entered into, given or instituted pursuant hereto or relating directly or indirectly hereto, be drawn up in English. Les parties reconnaissent avoir convenu que la rédaction du présente document sera en Anglais, ainsi que tous documents, avis et procédures judiciaires exécutés, donnés ou intentés, à la suite de ou en rapport, directement ou indirectement, avec les procédures concernées.

Graco Information

For the latest information about Graco products, visit www.graco.com.

For patent information, see www.graco.com/patents.

TO PLACE AN ORDER, contact your Graco distributor or call to identify the nearest distributor.

Phone: 612-623-6921 or Toll Free: 1-800-328-0211, Fax: 612-378-3505

All written and visual data contained in this document reflects the latest product information available at the time of publication. Graco reserves the right to make changes at any time without notice.

Original instructions. This manual contains English. MM 3A7467

Graco Headquarters: Minneapolis

International Offices: Belgium, China, Japan, Korea

**GRACO INC. AND SUBSIDIARIES • P.O. BOX 1441 • MINNEAPOLIS MN 55440-1441 • USA
Copyright 2020, Graco Inc. All Graco manufacturing locations are registered to ISO 9001.**

www.graco.com

Revision E, November 2020